

# Model 3200 Series Wet Bench Flame Detector

The various chemical vapors, acids and bases used in the semiconductor manufacturing wet benches pose a high potential for costly fires. Fires may result in costly damage to equipment, inventory and clean room facilities. Personnel injury and costly business interruptions are also likely. Factory Mutual requires electro-optical flame detectors in the semiconductor wet benches to monitor for fire. These flame detectors must be suitable for the hostile chemicals used in the etching process (such as hydrofluoric, sulfuric, and hydrochloric acids). Furthermore, they must be tested and approved for fire response to FR polypropylene now used in the construction of wet benches as well as other fuels such as isopropyl alcohol.

The Model 3200 easily adapts to most standard fire extinguishing systems and wet bench systems. It utilizes relay output for alarm and trouble and does not require special controllers or wiring / junction boxes.

The Model 3200 Flame Detector uses proven, stable UV/IR technology to continuously monitor for flame in wet bench applications. Using state-of-the-art micro-processor controlled fire algorithms, the Model 3200 can recognize different types of flame signatures while



rejecting common false alarms. Continuous self diagnostics perform tests of the detector operation. Each flame detector is tested to respond to a 4-inch diameter isopropyl alcohol (IPA) fire at 10 feet with a 120° field of view.

The standard Model 3200 has a sealed polypropylene housing designed to an IEC 529 IP67 rating for protection from a wide variety of acids and solvents. Thus occasional submersion by these chemicals will not damage the detector. The detector is rated over a wide operating temperature range for those applications where drying or heating elements are used. A version utilizing Polyvinylidene Fluoride (PVDF) is also available.

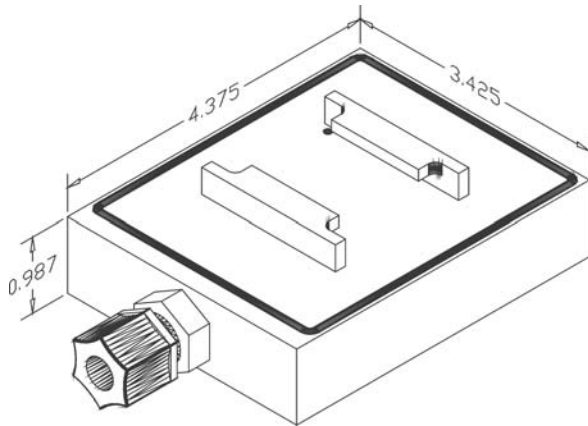

**Model 3200 Dimensions**

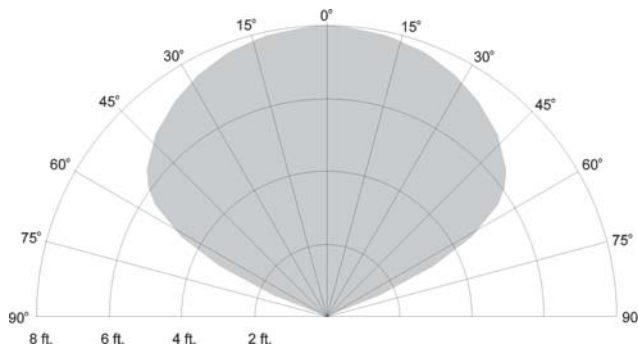

**Field of View**

Detector Response to Various Fuels			
Fuels	Distance	Fire Size	Response Time
Polypropylene	8 ft.	4 in. dia.	Less than 3 sec.
Isopropyl Alcohol	10 ft.	4 in. dia.	Less than 3 sec.
Heptane	40 ft.	1 sq. ft.	Less than 3 sec.
MEK	15 ft.	4 in. dia.	Less than 3 sec.
Silane	30 ft.	18 in. jet	Less than 3 sec.
Hydrogen	15 ft.	18 in. jet	Less than 3 sec.



# Model 3200 Series

# Flame Detectors

## Specifications

**Sensitivity:** 3.0 seconds to a 4 inch diameter isopropyl alcohol pan fire (on-axis) @ 10 feet

**Field of View:** 120° full cone

**False Alarm Immunity:** Does not alarm to sunlight, fluorescent lights, flashlights, or infrared heaters.

**Input Voltage:** 12 to 30 volts DC typically 24 VDC

**Current Draw:** @24 VDC; 28 mA normal mode; 54 mA alarm mode

**Operating Range**  
**Temperature:** Operating: 32° to 167°F (0° to 75° C)  
 Storage: -40° to 185° F ( -40° to 85° C)

**Humidity:** 10 to 90% RH

**Typical Fire Type:** FR & HB polypropylene and isopropyl alcohol

**Red LEDs:** Two, indicating Normal Operation and Trouble/Alarm

**Alarm Relay:** 1.0 amp @ 30 VDC resistive

**Trouble Relay:** 1.0 amp @ 30 VDC resistive

**UV Sensor:** Solar-blind Ultraviolet sensor - radiant energy in the 185 to 260 nm band

**IR Sensor:** Solid state infrared sensor detecting - IR energy in the .715 to 3.5 microns

**Acid/Solvent Resistant Surfaces:** Resistant to sulfuric acid, phosphoric acid, hydrofluoric acid, hydrochloric acid, ammonium hydroxide, nitric acid, isopropyl alcohol, deionized water, chromium phosphate, n-methyl-pyrrolidane, organic solvent base photoresist strips, ozone, etc.

**Housing:** FR Polypropylene (IP67, UL94 flamability rating V0) or (Polyvinylidene Fluoride - PVDF available) (for models -2X and -3X) with a 6 foot pigtail (8 wires standard - 4 wires for the fire relay, 2 wires for the trouble relay and 2 wires fro the power)

**Dimensions:** 3.4 x 4.2 x 1.0 inches (8.6 x 10.7 x 2.5 cm)

**Weight:** 1 lb (0.5 Kg)

**Approval:** FM Approved, CSFM 7210-1608:101

## Additional Features

**Self-Test Models:** Incorporate internal self-test for UV lamp

**Enhanced Models:** Incorporate internal self-test and a RS-485 computer interface for downloading real time spectral data pre-fire spectral data (includes 2 additional wires in pigtail)

False Alarm and Fire Response				
"This table shows the detectors ability to tolerate both modulated and unmodulated false alarm stimuli and still to detect a fire in the presence of the false alarm source (all fire tests used a 1.75" diameter alcohol pan fire at 6 feet)				
False Alarms Source	Distance	Unmodulated	Modulated	Response Time to Fire
Resistive Electric Heater 1320 Watt	6 Feet	No Response	No Response	Less than 3 sec.
Fluorescent Lights (2) 40 Watt Bulbs	6 Feet	No Response	No Response	Less than 3 sec.
Halogen Light 500 Watt	10 Feet	No Response	No Response	Less than 3 sec.
Incandescent Light 100 Watt	6 Feet	No Response	No Response	Less than 3 sec.

Ordering Information		Built-in Sensor Self-test	Fire Relay Contacts	Fault Relay Contacts*
3200-01	Standard	NO	Normally Open	Normally Closed
3200-02	Self-test	YES	Normally Open	Normally Closed
3200-03	Enhanced	YES	Normally Open	Normally Closed
3200-04	Standard, with SealCon and Turk connectors	NO	Normally Closed	Normally Closed
<b>Options:</b>				
3240-01	Flame Detector Tester (for Model 3200 Flame Detector)			

\* This is with the detector operating normally and the fault relay energized.