



FieldServer
FS-8704-16 Omron FINS
Driver Manual
(Supplement to the FieldServer Instruction Manual)

APPLICABILITY & EFFECTIVITY

Effective for all systems manufactured after August 2017.

Driver Version: 1.02
Document Revision: 2.B

Technical Support

Please call us for any technical support needs related to the FieldServer product.

Sierra Monitor Corporation
1991 Tarob Court
Milpitas, CA 95035

Website: www.sierramonitor.com

U.S. Support Information:

+1 408 262-6611

+1 800 727-4377

Email: support@sierramonitor.com

EMEA Support Information:

+44 2033 1813 41

Email: support.emea@sierramonitor.com

TABLE OF CONTENTS

- 1 Omron FINS Description 4**
- 2 Driver Scope of Supply 4**
 - 2.1 Supplied by Sierra Monitor Corporation 4
 - 2.2 Provided by the Supplier of 3rd Party Equipment..... 4
 - 2.2.1 Required 3rd Party Hardware..... 4
 - 2.2.2 Required 3rd Party Software 4
 - 2.2.3 Required 3rd Party Configuration..... 4
- 3 Hardware Connections..... 5**
 - 3.1 Hardware Connection Tips / Hints..... 5
 - 3.2 Example of Omron PLC Configuration Using Omron ETN11 Module..... 6
- 4 Configuring the FieldServer as a FINS Client 8**
 - 4.1 Data Arrays/Descriptors 8
 - 4.2 Driver Specific FieldServer Parameters 9
 - 4.3 Client Side Connection Descriptors..... 9
 - 4.4 Client Side Node Descriptors 10
 - 4.5 Client Side Map Descriptors 11
 - 4.5.1 FieldServer Related Map Descriptor Parameters 11
 - 4.5.2 Driver Related Map Descriptor Parameters 11
 - 4.5.3 Timing Parameters 11
 - 4.5.4 Map Descriptor Example 1: IO Read 12
 - 4.5.5 Map Descriptor Example 2: IO Write..... 13
 - 4.5.1 Map Descriptor Example 3: Clock Read 13
 - 4.5.2 Map Descriptor Example 4: Clock Write 14
 - 4.5.3 Map Descriptor Example 5: Read CPU Cycle Times..... 14
 - 4.5.4 Map Descriptor Example 6: Run-Stop PLC..... 14
 - 4.5.5 Map Descriptor Example 7: Read CPU Status 14
- 5 Configuring the FieldServer as a FINS Server 15**
 - 5.1 Server Side Connection Descriptors 15
 - 5.2 Server Side Node Descriptors 16
 - 5.3 Server Side Map Descriptors..... 17
 - 5.3.1 FieldServer Specific Map Descriptor Parameters 17
 - 5.3.2 Driver Specific Map Descriptor Parameters 17
 - 5.3.3 Map Descriptor Example 1: IO Read 18
 - 5.3.4 Map Descriptor Example 2: IO Write..... 18
 - 5.3.5 Map Descriptor Example 3: Clock Read 19
 - 5.3.6 Map Descriptor Example 4: Clock Write 19
 - 5.3.7 Map Descriptor Example 5: CPU Cycle Times 19
 - 5.3.8 Map Descriptor Example 6: Run-Stop PLC..... 19
 - 5.3.9 Map Descriptor Example 7: CPU Status 19
- Appendix A Advanced Topics 20**
 - Appendix A.1. Driver Map Descriptor Parameter’s Bounds 20
 - Appendix A.2. PLC Status to Execute Commands 21
 - Appendix A.3. End Codes 22
- Appendix B Driver Notes..... 28**
 - Appendix B.1 Data Storage 28
 - Appendix B.2 Driver Stats 30
 - Appendix B.3 Driver Error Messages 31
- Appendix C TROUBLESHOOTING 32**
 - Appendix C.1 Connection Tips & Hints 32
 - Appendix C.1.1 Example: Class B Addressing..... 32
 - Appendix C.1.2 Example: Class A Addressing..... 33

1 OMRON FINS DESCRIPTION

The Ethernet Omron FINS driver allows the FieldServer to transfer data to and from devices over Ethernet using Omron FINS protocol. The FieldServer can emulate either a Server or Client.

FINS is an Omron protocol which can be used by a PLC program to transfer data and perform other services with a remote PLC connected on an Ethernet Network. It can also be used by remote devices such as PC's and FieldServer's to transfer data and perform other services.

The protocol uses the Ethernet protocol called UDP to carry the FINS messages back and forth. The UDP protocol is not connection based and reliability is achieved by using confirmation messages.

This Ethernet Driver can be used to transfer data to and from the Nodes supporting FINS communications.

Max Nodes Supported

FieldServer Mode	Nodes	Comments
Client	126	Omron limit the set of permitted nodes to 126. They are numbered 1 to 126 corresponding to the last byte of the remote node IP address.
Server	20	The FieldServer can emulate a maximum of 20 Omron FINS servers.

2 DRIVER SCOPE OF SUPPLY

2.1 Supplied by Sierra Monitor Corporation

PART #	Description
FS-8915-10	UTP cable (7 foot) for Ethernet connection

2.2 Provided by the Supplier of 3rd Party Equipment

2.2.1 Required 3rd Party Hardware
None.

2.2.2 Required 3rd Party Software
CX-Programmer Software or any other compatible software by Omron to setup the PLC.

2.2.3 Required 3rd Party Configuration
The Omron PLC device needs to be set into the Automatic Address Generation mode using the CX-Programmer or any other compatible software.

3 HARDWARE CONNECTIONS

The FieldServer is connected to the PLC as shown in connection drawing.

Configure the PLC according to manufacturer's instructions to work with other FINS supported device.

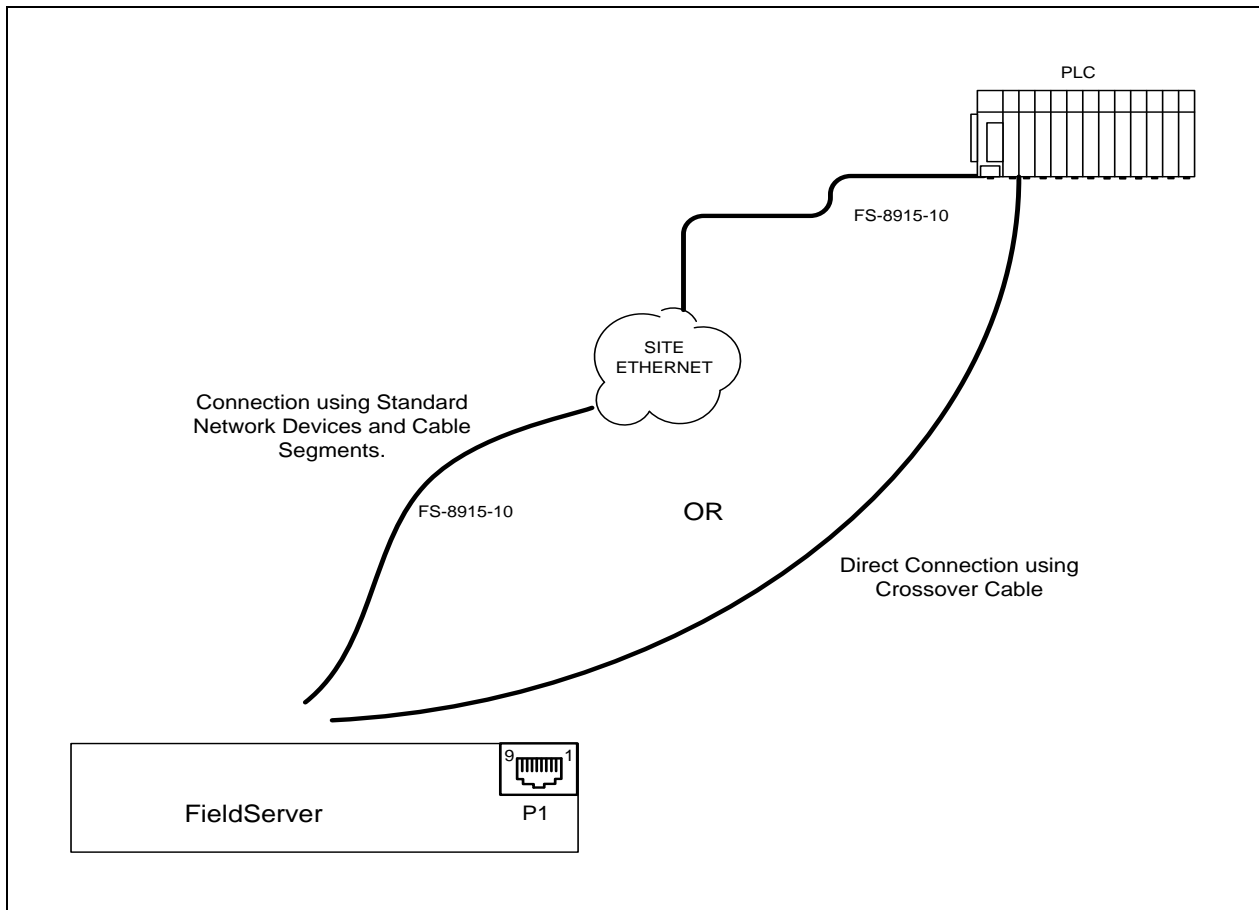

3.1 Hardware Connection Tips / Hints

If communication doesn't start check the following.

Are the FieldServer and PLC on the same network?

Are all intended Nodes configured to communicate on FINS?

Are all FINS Nodes configured to use the same Port Number?

Is the Network healthy?

3.2 Example of Omron PLC Configuration Using Omron ETN11 Module

Setting the Node Number¹

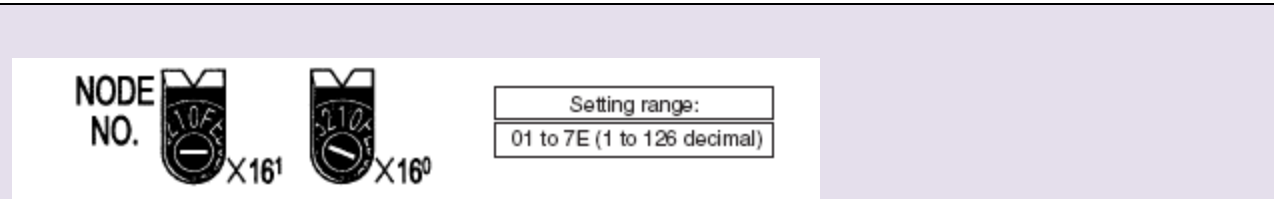

The diagram shows two rotary switches labeled 'X16¹' and 'X16⁰'. The left switch is set to '01' and the right switch is set to '00'. To the right is a table:

Setting range:
01 to 7E (1 to 126 decimal)

With the FINS communications service, when there are multiple Ethernet Units connected to the Ethernet network, the Ethernet Units are identified by node numbers. Use the node number switches to set the node number between 01 and 7E hexadecimal (1 to 126 decimal). Do not set a number that has already been set for another node on the same network.

The left switch sets the sixteens digit (most significant digit) and the right switch sets the ones digit (least significant digit). The node number is factory set to 01. When using the automatic generation method for address conversion, set the node number to the same value as that of the local IP address switches. If this is not possible, then either the IP address table method or the combined method must be used for address conversion. For details, refer to *4-2 CPU*

Bus Unit System Setup. If the FINS communications service is not being used over the Ethernet network, then there is no problem if the node number duplicates that of another Ethernet Unit. The node number must still be set from 01 to 7E, however, or the ERC indicator will light.

NOTE: Turn OFF the power supply before setting the node number.

¹ The following information is extracted from the Omron Manual "W343-E1-05 9/03".

Setting the Local IP Address

The nodes on an Ethernet network are identified by IP addresses. Each IP address is set with 32 bits of binary data. These 32 bits are divided into four 8-bit fields called octets, and each octet is expressed as four decimal numbers. At CS-series Ethernet Units, four bits are expressed as a hexadecimal digit, and the eight hexadecimal rotary switches (the local IP address switches) on the back of the Unit are used to set the local IP address. Set the eight switches in hexadecimal as shown below, combining SW1 and SW2, SW3 and SW4, SW5 and SW6, and SW7 and SW8. Each switch can be set from 0 to F.

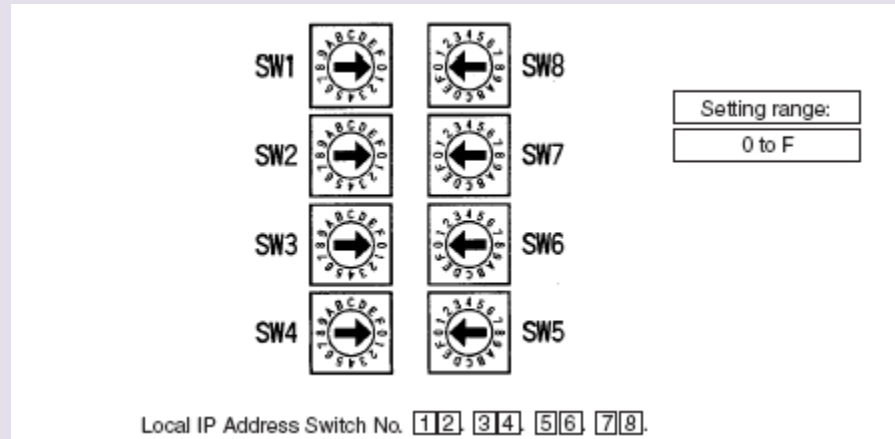

The switches are all factory-set to 0 (00.00.00.00). The Ethernet Unit cannot be used with this setting; a proper IP address must be set.

The following settings cannot be made for the IP address, or the ERC indicator will flash.

All bits in the network number field set to 0 or 1.

All bits in the host number field set to 0 or 1.

All bits in the subnet number field set to 1.

The beginning of the IP address set to 127 (7F Hex) Example: 127.35.21.16

NOTES:

1. When using the automatic generation method for address conversion, set switches 7 and 8 to the same values as the node number setting, and set the rest of the host number to zeroes. For details regarding the host number, refer to *1-7 IP Addresses*. The value for the host number field in the IP address must match the value for the node number or the ERC indicator will flash.

2. If a subnet mask is to be set, use the CX-Programmer to set it in the CPU Bus Unit System Setup. For details, refer to *4-2 CPU Bus Unit System Setup*.

4 CONFIGURING THE FIELDSEVER AS A FINS CLIENT

For detailed information on FieldServer configuration, refer to the FieldServer Configuration Manual. The information that follows describes how to expand upon the factory defaults provided in the configuration files included with the FieldServer (see “.csv” sample files provided with the FieldServer).

This section documents and describes the parameters necessary for configuring the FieldServer to communicate with a FINS Server. As a Client this driver reads and writes data to Server Nodes. Server nodes should be FINS capable and be configured to communicate over FINS.

4.1 Data Arrays/Descriptors

The configuration file tells the FieldServer about its interfaces, and the routing of data required. In order to enable the FieldServer for FINS communications, the driver independent FieldServer buffers need to be declared in the “Data Arrays” section, the destination device addresses need to be declared in the “Client Side Nodes” section, and the data required from the servers needs to be mapped in the “Client Side Map Descriptors” section. Details on how to do this can be found below.

NOTE: In the tables below, * indicates an optional parameter and bold legal values are the default.

Section Title		
Data_Arrays		
Column Title	Function	Legal Values
Data_Array_Name	Provide name for Data Array	Up to 15 alphanumeric characters
Data_Array_Format	Provide data format. Each Data Array can only take on one format.	Float, Bit, UInt16, SInt16, Packed_Bit, Byte, Packed_Byte, Swapped_Byte
Data_Array_Length	Number of Data Objects. Must be larger than the data storage area required by the Map Descriptors for the data being placed in this array.	1-32767

Example

```

// Data Arrays

Data_Arrays
Data_Array_Name      ,Data_Format      ,Data_Array_Length,
DA_CIO              ,UInt16           ,5143
DA_WR               ,UInt16           ,511
DA_HR               ,UInt16           ,511
DA_DM               ,UInt16           ,32767
```

4.2 Driver Specific FieldServer Parameters

Section Title		
FieldServer		
Column Title	Function	Legal Values
Title	Name for FieldServer.	Text
System_Node_Id	Specify physical node Id on network. This is the last byte of the IP Address of the FieldServer. eg. If FieldServer's IP Address is 192.168.1.81 then this parameter should be set to 81.	1-126

Example

```
// FieldServer Driver specific parameters

FieldServer
Title           , System_Node_Id
Fins Client     , 81
```

4.3 Client Side Connection Descriptors

Section Title		
Adapter		
Column Title	Function	Legal Values
Adapter	Adapter Name	N1, N22
Protocol	Specify protocol used.	Fins, omn_fins or fins_udp
Udp_port_number	Specify UDP port number.	0, 9600 etc.

Example

```
// Client Side

Connections
Adapters
Adapter       , Protocol       , Udp_port_number
N1           , Fins           , 9600
```

² Not all ports shown are necessarily supported by the hardware. Consult the appropriate Instruction manual for details of the ports available on specific hardware.

4.4 Client Side Node Descriptors

Section Title		
Nodes		
Column Title	Function	Legal Values
Node_Name	Provide name for node.	Up to 32 alphanumeric characters
IP_Address	Provide IP Address of PLC.	Eg. 192.168.1.105
Node_ID	Node number set at PLC. The node number should correspond to the last byte of the IP address. Eg. 105 corresponds to the example IP address above.	1-126
Protocol	Specify protocol used.	Fins, omn_fins or fins_udp
Adapter	Specify which port the device is connected to the FieldServer.	N1, N23
*Net_Number	Provide the network number of PLC.	1-255

Example

```
// Client Side Nodes

Nodes
Node_Name      , IP_Address  , Node_ID  , Protocol  , Adapter  , Net_Number
PLC 1          , 192.168.1.5 , 1        , Fins      , N1       , 1
```

³ Not all ports shown are necessarily supported by the hardware. Consult the appropriate Instruction manual for details of the ports available on specific hardware.

4.5 Client Side Map Descriptors

4.5.1 FieldServer Related Map Descriptor Parameters

Column Title	Function	Legal Values
Map_Descriptor_Name	Name of this Map Descriptor.	Up to 32 alphanumeric characters
Data_Array_Name	Name of Data Array where data is to be stored in the FieldServer.	One of the Data Array names from "Data Array" section above
Data_Array_Offset	Starting location in Data Array.	0 to maximum specified in "Data Array" section above
Function	Function of Client Map Descriptor.	RDBC, WRBC, WRBX

4.5.2 Driver Related Map Descriptor Parameters

Column Title	Function	Legal Values
Node_Name	Name of Node to fetch data from.	One of the node names specified in "Client Node Descriptor" above
Data_Type*	Data type (Appendix A.1).	CIO-WORD, WR-WORD, HR-WORD, AR-WORD, EM-WORD
Length	Length of Map Descriptor	1- 729
Address	Starting address of read block.	0, 1, 100, etc; see Appendix A.1 for details
Memory_Code*	Memory code for PLC memory type (Appendix A.1).	B0, B1, B2, B3, 82, 98 and A0 ---- AC
Command_Name	Name of the command (Appendix A.1).	MEMORY AREA READ MEMORY AREA WRITE RUN-STOP CLOCK READ CLOCK WRITE CYCLE TIME READ CPU UNIT STATUS READ
MRC*	Main Request Code (Appendix A.1).	1,4,6,7
SRC*	Sub Request Code (Appendix A.1).	1,2,20
Unit_Number*	Unit number of CPU at PLC.	0,1,2 etc

4.5.3 Timing Parameters

Column Title	Function	Legal Values
Scan_Interval	Rate at which data is polled	≥0.001s

4.5.4 Map Descriptor Example 1: IO Read

This example provides all the required information to read and write to the IO memory area of the PLC. The following Map Descriptor creates a task for the driver to read the first 20 Words from the CIO memory area and store them in the Data Array DA_CIO. The first word from the PLC will be stored as the first element in the Data Array. Whenever an upstream device writes any element in the Data Array, the Driver will write the same value to the PLC at the corresponding address. This scheme is known as Write-thru. In this example the Driver can write only one value at a time.

Map_Descriptor_Name	Data_Array_Name	Data_Array_Offset	Function	Node_Name	Address	Length	Data_Type	Command_Name	Unit_number
CMD_CIO	DA_CIO	0	RDBC	PLC1	0	20	CIO-WORD	MEMORY AREA READ	0

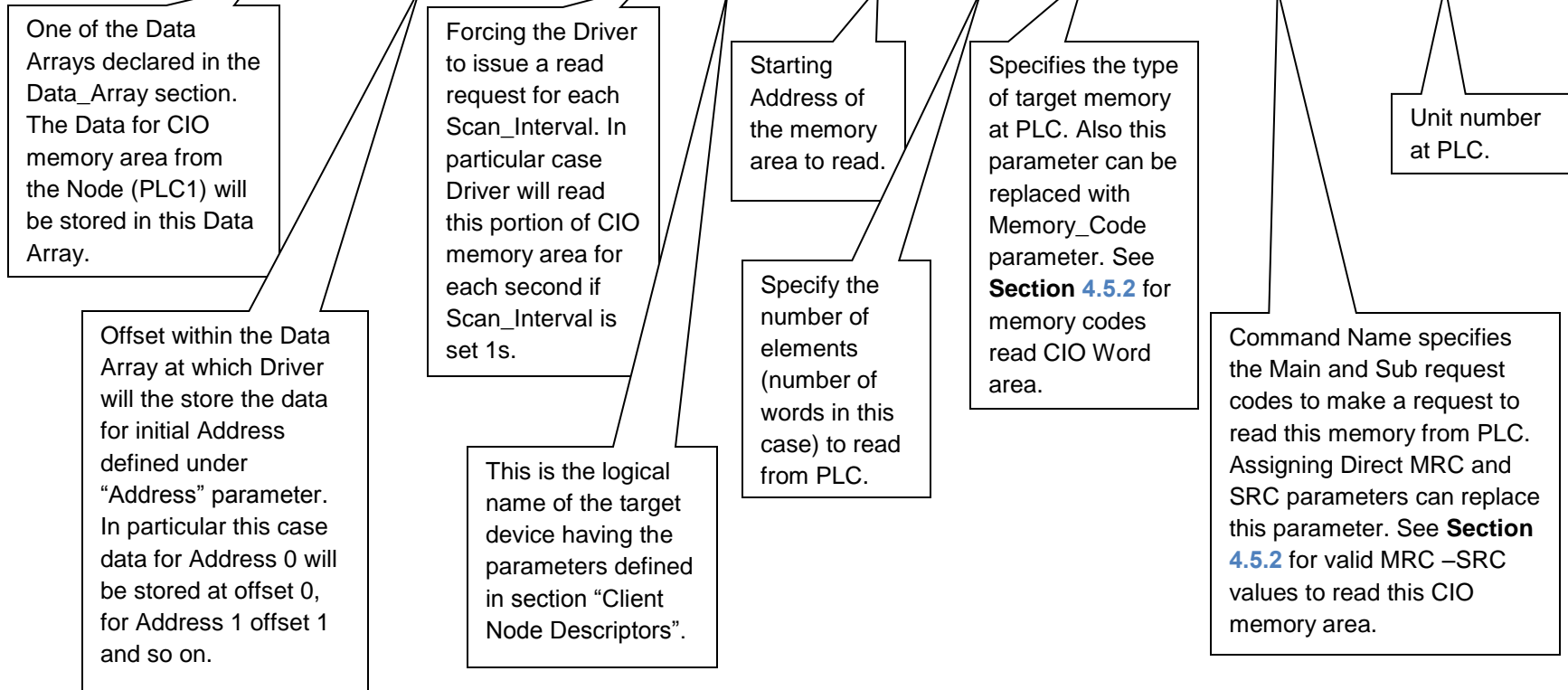

4.5.5 Map Descriptor Example 2: IO Write

This example is used to write a value(s) to the PLC. The write is done when the contents of the Data Array are updated (written to by a remote device). In the previous example, it was shown how a 'read' Map Descriptor can also be used to write by using FieldServer's write-through technology.

Map_Descriptor_Name	Data_Array_Name	Data_Array_Offset	Function	Node_name	Address	Length	Data_type	Command_Name	Unit_Number
CMD_CIOw	DA_CIOw	, 0	, WRBX	, PLC1	, 0	, 20	, CIO-WORD	, MEMORY AREA WRITE	, 0

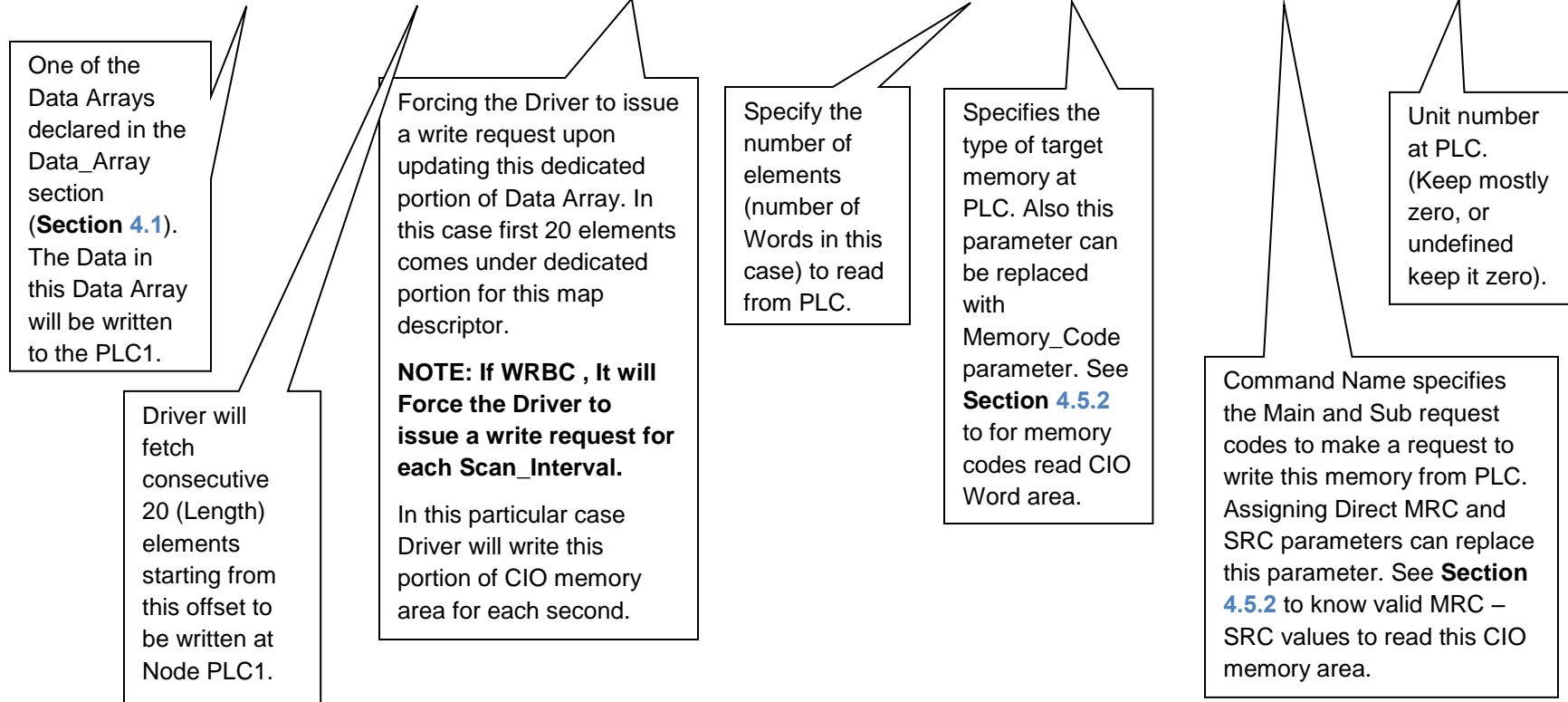

4.5.1 Map Descriptor Example 3: Clock Read

This Map Descriptor reads the PLC clock and stores the information in a Data Array DA_CLK. For detail on how the Driver stores clock information see [Appendix A](#).

Map_Descriptor_Name	Data_Array_Name	Data_Array_Offset	Function	Node_Name	Length	Command_Name	Unit_Number
CMD_CLKr	, DA_CLKr	, 0	, RDRC	, PLC1	, 7	, CLOCK READ	, 0

4.5.2 Map Descriptor Example 4: Clock Write

Write-thru is not possible for Clock write. A dedicated Map Descriptor is required to overwrite the PLC clock. This Map Descriptor overwrites the clock whenever an upstream device updates the DA_CLKw Data Array. See [Appendix A](#) for details.

Map_Descriptor_Name	Data_Array_Name	Data_Array_Offset	Function	Node_Name	Length	Command_Name	Unit_Number
CMD_CLKw	DA_CLKw	0	WRBX	PLC1	7	CLOCK WRITE	0

NOTE: All elements must be updated in DA_CLKw to set the clock as expected. Whenever any element updates, the Driver will write all seven values to the PLC along with the one updated value. If all elements are updated by the upstream device in a single operation then the Driver will also set the all elements at the PLC in a single operation.

4.5.3 Map Descriptor Example 5: Read CPU Cycle Times

This Map Descriptor reads the CPU cycle time at the PLC and stores the data in a Data Array DA_CYCT. Average, maximum and minimum cycle times will be stored in three consecutive locations starting with the location indicated by the Data_Array_Offset parameter. See [Appendix A](#).

Map_Descriptor_Name	Data_Array_Name	Data_Array_Offset	Function	Node_Name	Length	Command_Name	Unit_Number
CMD_CYCT	DA_CYCT	0	RDBC	PLC1	3	CLOCK READ	0s

The Driver stores these values as it gets them from the PLC. Scaling can provided to determine the unit in which the value is stored. Default is 10 times milliseconds.

4.5.4 Map Descriptor Example 6: Run-Stop PLC

Defining this Map Descriptor Driver can change the PLC mode to STOP (Program), MONITOR or RUN mode. The Driver issues a change mode command to the PLC whenever the value at the declared offset is updated.

Map_Descriptor_Name	Data_Array_Name	Data_Array_Offset	Function	Node_name	Length	Command_Name	Unit_Number
CMD_RUN_ST	DA_RUN_ST	0	WRBX	PLC1	1	RUN-STOP	0s

The Driver will change PLC modes depending upon the value poked by the upstream device at offset (0 in this case). See [Appendix A](#) for values corresponding to PLC modes.

4.5.5 Map Descriptor Example 7: Read CPU Status

Defining this Map Descriptor Driver reads the CPU status and stores it in the Data Array DA_STATUS.

Map_Descriptor_Name	Data_Array_Name	Data_Array_Offset	Function	Node_name	Length	Command_Name	Unit_Number
CMD_STATUS	DA_STATUS	0	REBC	PLC1	67	CPU UNIT STATUS READ	0s

The Driver stores the status information in the named Data Array at consecutive locations starting with Data_Array_Offset. See [Appendix A](#) for further information.

5 CONFIGURING THE FIELDSEVER AS A FINS SERVER

For detailed information on FieldServer configuration, refer to the FieldServer Configuration Manual. The information that follows describes how to expand upon the factory defaults provided in the configuration files included with the FieldServer (see “.csv” files on the driver CD).

This section documents and describes the parameters necessary for configuring the FieldServer to communicate with a FINS Client.

As a Server, the Driver responses to read requests and updates the FieldServer Data Arrays with write requests from the Client.

The configuration file tells the FieldServer about its interfaces, and the routing of data required. In order to enable the FieldServer for FINS communications, the driver independent FieldServer buffers need to be declared in the “Data Arrays” section, the FieldServer virtual node(s) needs to be declared in the “Server Side Nodes” section, and the data to be provided to the client’s needs to be mapped in the “Server Side Map Descriptors” section. Details on how to do this can be found below.

NOTE: In the tables below, * indicates an optional parameter and the bold legal values are default.

5.1 Server Side Connection Descriptors

Section Title		
Adapter		
Column Title	Function	Legal Values
Adapter	Adapter Name.	N1, N24
Protocol	Specify protocol used.	Fins, omn_fins or fins_udp
Udp_port_number	Specify UDP port number.	0,9600 etc.

Example

```
//Server Side
Connections

Adapters
Adapter          , Protocol          , Udp_port_number
N1               , Fins                , 9600
```

⁴ Not all ports shown are necessarily supported by the hardware. Consult the appropriate Instruction manual for details of the ports available on specific hardware.

5.2 Server Side Node Descriptors

Section Title		
Nodes		
Column Title	Function	Legal Values
Node_Name	Provide name for node.	Up to 32 alphanumeric characters
Node_ID	Virtual Node number of FINS server.	1-126
Protocol	Specify protocol used.	Fins, omn_fins or fins_udp
Server_Hold_Timeout*	Specifies time FieldServer will reserve server side connection while waiting for the Client side to update data in Data_Array (if necessary).	>1.0s
Net_Number	Provide the network number of FINS Server network.	1-255

Example

```
// Server Side Nodes

Nodes
Node_Name          , Node_ID          , Protocol          , Net_Numer
PLC 1              , 1              , Modbus_RTU, , 1
```

5.3 Server Side Map Descriptors

5.3.1 FieldServer Specific Map Descriptor Parameters

Column Title	Function	Legal Values
Map_Descriptor_Name	Name of this Map Descriptor.	Up to 32 alphanumeric characters
Data_Array_Name	Name of Data Array where data is to be stored in the FieldServer.	One of the Data Array names from "Data Array" section above
Data_Array_Offset	Starting location in Data Array.	0 to maximum specified in "Data Array" section above
Function	Function of Server Map Descriptor.	Server

5.3.2 Driver Specific Map Descriptor Parameters

Column Title	Function	Legal Values
Node_Name	Name of Node to fetch data from.	One of the node names specified in "Server Node Descriptor" above
Data_Type*	Data type (Appendix A.1).	CIO-WORD, WR-WORD, HR-WORD, AR-WORD, EM-WORD
Length	Length of Map Descriptor.	1 to maximum specified in Data Array section above
Address*	Starting address of read block.	0,100, 32767 etc.; see Appendix A.1 for details
Memory_Code*	Memory code for PLC memory type (Appendix A.1).	B0, B1, B2, B3, 82, 98 and A0 ---- AC
Command_Name*	Name of the command (Appendix A.1).	MEMORY AREA READ MEMORY AREA WRITE RUN-STOP CLOCK READ CLOCK WRITE CYCLE TIME READ CPU UNIT STATUS READ
MRC*	Main Request Code (Appendix A.1).	1,4,6,7
SRC*	Sub Request Code (Appendix A.1).	1,2,20
Unit_Number*	Unit number of CPU at PLC.	0,1,2 etc.

5.3.3 Map Descriptor Example 1: IO Read

The following Map Descriptor enables the Driver to serve the clients for CIO memory operations. The Command_Name “MEMORY AREA READ” makes this memory readable.

Map_Descriptor_Name	Data_Array_Name	Data_Array_Offset	Function	Node_Name	Address	Length	Data_Type	Command_Name	Unit_Number
SRV_CIOr	DA_CIO	0	SERVER	PLC1	0	6143	CIO-WORD	MEMORY AREA READ	0

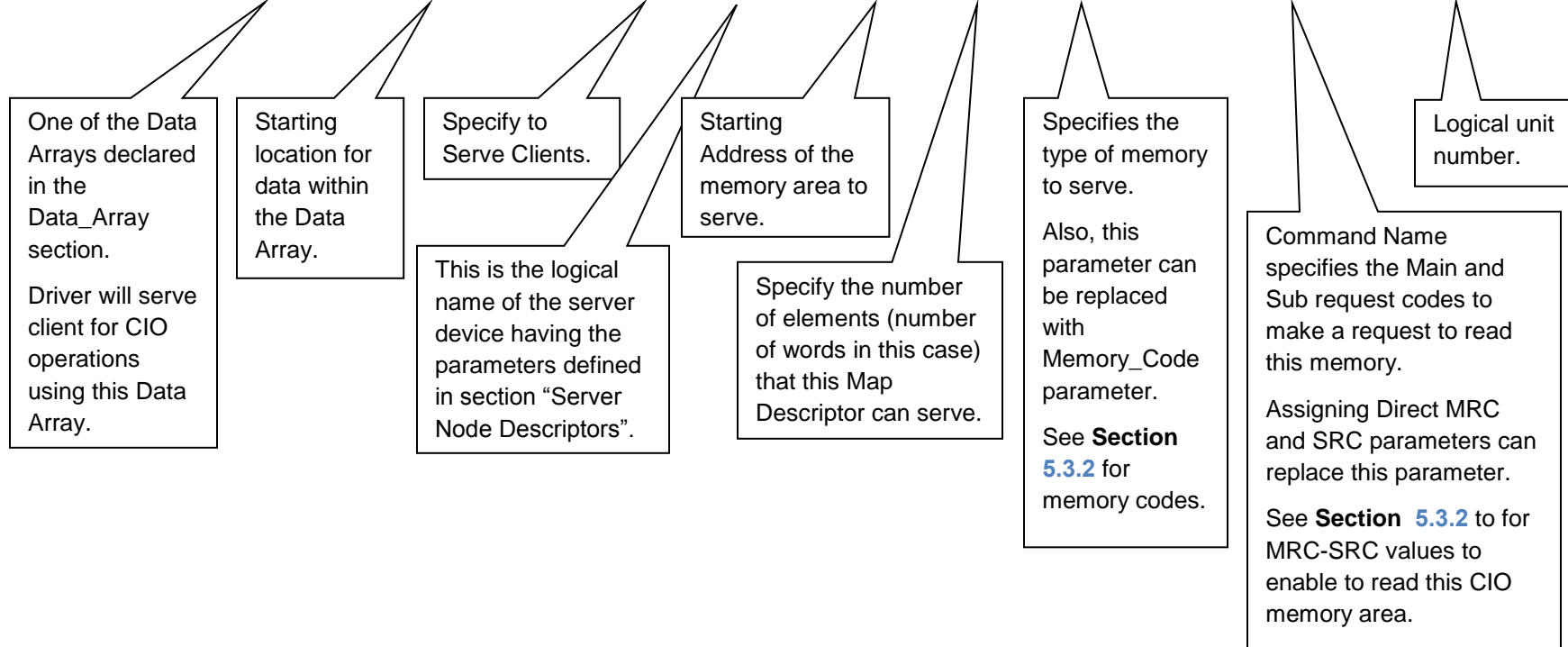

5.3.4 Map Descriptor Example 2: IO Write

This Map Descriptor makes the memory area writable which was made readable by the previous Map Descriptor. Thus memory area can be made read only, write only or read and write enabled.

Map_Descriptor_Name	Data_Array_Name	Data_Array_Offset	Function	Node_Name	Address	Length	Data_Type	Command_Name	Unit_number
SRV_CIOw	DA_CIO	0	SERVER	PLC1	0	6143	CIO-WORD	MEMORY AREA WRITE	0

5.3.5 Map Descriptor Example 3: Clock Read

This Map Descriptor enables the driver to serve the client with a clock read request. See [Appendix A](#) for further information.

Map_Descriptor_Name	Data_Array_Name	Data_Array_Offset	Function	Node_Name	Length	Command_Name	Unit_Number
SRV_CLKr	DA_CLKr	, 0	, SERVER	, PLC1	, 7	, CLOCK READ	, 0s

5.3.6 Map Descriptor Example 4: Clock Write

This Map Descriptor allows updating clock information when the Client makes a clock write request. See [Appendix A](#) for more information.

Map_Descriptor_Name	Data_Array_Name	Data_Array_Offset	Function	Node_name	Length	Command_Name	Unit_Number
SRV_CLKr	DA_CLKr	, 0	, SERVER	, PLC1	, 7	, CLOCK WRITE	, 0

5.3.7 Map Descriptor Example 5: CPU Cycle Times

This Map Descriptor enables the driver to serve Clients with CPU cycle time information upon request. See [Appendix A](#) for further information.

Map_Descriptor_Name	Data_Array_Name	Data_Array_Offset	Function	Node_Name	Length	Command_Name	Unit_Number
SRV_CYCT	DA_CYCT	, 0	, SERVER	, PLC1	, 7	, CLOCK READ	, 0

5.3.8 Map Descriptor Example 6: Run-Stop PLC

This Map Descriptor allows the Client to change the Server's Operating Mode. See [Appendix A](#) for stored values corresponding to PLC modes.

Map_Descriptor_Name	Data_Array_Name	Data_Array_Offset	Function	Node_Name	Length	Command_Name	Unit_Number
SRV_RUN_ST	DA_RUN_ST	, 0	, SERVER	, PLC1	, 1	, RUN-STOP	, 0

5.3.9 Map Descriptor Example 7: CPU Status

This Map Descriptor enables the driver to respond to clients requesting CPU status. See [Appendix A](#) for further information.

Map_Descriptor_Name	Data_Array_Name	Data_Array_Offset	Function	Node_Name	Length	Command_Name	Unit_Number
SRV_STATUS	DA_STATUS	, 0	, SERVER	, PLC1	, 67	, CPU UNIT STATUS READ	, 0

APPENDIX A ADVANCED TOPICS

Appendix A.1. Driver Map Descriptor Parameter's Bounds

Most Map Descriptors need to know the following:

<p>The Data Type to be read or written</p>	<p>Specify Either</p> <p>a) Data Type or</p> <p>b) Memory Code</p> <p>This is how the driver determines which memory area of the PLC must be processed (for EM Banks only the Memory_Code can be specified).</p>
<p>The Command to be executed</p>	<p>Specify either</p> <p>a) The command name or</p> <p>b) The MRC/SRC Pair</p>

Memory Type	Data_Type	Memory_Code	Command_Name	MRC	SRC	Address
I/O Memory	CIO-WORD	B0	MEMORY AREA READ	1	1	0-6143
			MEMORY AREA WRITE	1	2	0-6143
	WR-WORD	B1	MEMORY AREA READ	1	1	0-511
			MEMORY AREA WRITE	1	2	0-511
	HR-WORD	B2	MEMORY AREA READ	1	1	0-511
			MEMORY AREA WRITE	1	2	0-511
	AR-WORD	B3	MEMORY AREA READ	1	1	0-959
			MEMORY AREA WRITE	1	2	448-959
	DM-WORD	82	MEMORY AREA READ	1	1	0-32767
			MEMORY AREA WRITE	1	2	0-32767
	EM-WORD	98 Present Current EM Bank	MEMORY AREA READ	1	1	0-32767
			MEMORY AREA WRITE	1	2	0-32767
	Not Available (Use only memory_code)	A0-AC (Any other EM Bank)	MEMORY AREA READ	1	1	0-32767
			MEMORY AREA WRITE	1	2	0-32767

Appendix A.2. PLC Status to Execute Commands

PLC Type	Memory Type	Command name	Run Mode	Monitor Mode	Program Mode	Access Right ⁵	UM Read Protection ⁶	DIP UM Protection ⁷
CS1/CJ1 Series	I/O Memory	MEMORY AREA READ	OK	OK	OK	OK	OK	OK
		MEMORY AREA WRITE	OK	OK	OK	OK	OK	OK
	Operating Mode Changes	RUN	OK	OK	OK	Disabled	OK	OK
		STOP	OK	OK	OK	Disabled	OK	OK
	Time Data Access	CLOCK READ	OK	OK	OK	OK	OK	OK
		CLOCK WRITE	OK	OK	OK	Disabled	OK	OK
	Status Reading	CPU UNIT STATUS READ	OK	OK	OK	OK	OK	OK
		CYCLE TIME READ	OK	OK	Disabled	OK	OK	OK

⁵ Access Right at Other Device: The Access right at other device column tells whether the CPU Unit can or cannot receive a command when another device has the access right to the CPU Unit.

⁶ UM Read Protection: The UM read protection column tells whether the CPU Unit can or cannot receive the command when UM (user memory) is protected from a Peripheral Device.

⁷ DIP Switch UM Protection: The DIP switch UM protection column tells whether the CPU Unit can or cannot receive a command when UM is write-protected by turning ON pin 1 of the DIP switch on the CPU Unit's front panel.

Appendix A.3. End Codes

The following table lists the main codes and the sub-codes, which combine to form the end code (response code) returned for a FINS command. The probable cause and corrections for each error code are also given. Depending on the command, the destination code will sometimes make a request of another node on a network. The other node is referred to as the third Node.⁸

Main code	Subcode	Check point	Probable cause	Correction
00: Normal completion	00: Normal completion	---	---	---
	01: Service canceled	---	Service was cancelled.	Check the capacity of the destination area in the third node.
		Data link status	Service was cancelled.	Check the status of the data link.
01: Local node error	01: Local node not in network	Network status of local node	Local node is not participating in the network.	Connect the node to the network.
	02: Token timeout	Maximum node address	Token doesn't arrive.	Set the local node to within the maximum node address.
	03: Retries failed	---	Send was not possible during the specified number of retries.	Execute a communications test between the nodes and re-examine the system environment if it fails.
	04: Too many send frames	Number of enabled send frames	Cannot send because maximum number of event frames exceeded.	Check event execution on the network and reduce the number of events per cycle. Increase the maximum number of event frames.
	05: Node address range error	Node address	Node address setting error occurred.	Check the settings of the rotary switches to be sure that the address is within range and that each address is set only once in the same network.
	06: Node address duplication	Node addresses	The same node address has been set twice in the same network.	Change the address of one of the nodes with the same address.
02: Destination node error	01: Destination node not in network	INS indicator on Unit	The destination node is not in the network.	Add the destination node to the network.
	02: Unit missing	Instruction control data	There is no Unit with the specified unit address.	Check the destination unit address.
		03: Third node missing	Instruction control data	The third node does not exist.
	Command data		Broadcasting was specified.	Specify only one node for the third node.
	04: Destination node busy	---	The destination node is busy.	Increase the number of retries or review the system so that the destination node does not receive so many messages.
	05: Response timeout	---	The message was destroyed by noise.	Increase the number of retries or test communications between nodes to see if there is too much noise.
		Instruction control data	The response monitor time is too short.	Increase the length of the response monitor time.
Error history		The send/receive frame was discarded.	Take appropriate measures based on the error history.	

⁸ This section is a reproduction of Section 5-1-3 End Codes from Omron Communication Commands Reference Manual (M11W342e160603.pdf).

Main code	Subcode	Check point	Probable cause	Correction
03: Controller error	01: Communications controller error	Unit/Board indicators	An error occurred in the communications controller.	Take appropriate measures based on the operation manuals for the related Units/Boards.
	02: CPU Unit error	CPU Unit indicators at destination node	A CPU error occurred in the destination CPU Unit.	Clear the error from the CPU Unit based on its operation manuals.
	03: Controller error	Board indicators	A response was not returned because an error occurred in the Board.	Check network communications status and restart the Board. If the problem persists, replace the Board.
	04: Unit number error	Unit number	The unit number was set incorrectly.	Set the rotary switches correctly, being sure the unit numbers are within range and that each number is used only once.
04: Service unsupported	01: Undefined command	Command code	The Unit/Board does not support the specified command code.	Check the command code.
	02: Not supported by model/version	Unit model and version	The command cannot be executed because the model or version is incorrect.	Check the model number and version.
05: Routing table error	01: Destination address setting error	Routing table	The destination network or node address is not set in the routing tables.	Register the destination network and node in the routing tables.
	02: No routing tables	Routing table	Relaying is not possible because there are no routing tables.	Set routing tables in the source node, designation node, and relay nodes.
	03: Routing table error	Routing table	There is an error in the routing tables.	Set the routing tables correctly.
	04: Too many relays	Network configuration	An attempt was made to send to a network that was over 3 networks away	Reconstruct the networks or change the routing tables so that commands are sent within a range of 3 networks or less.
10: Command format error	01: Command too long	Command data	The command is longer than the maximum permissible length.	Check the command format and correct the command data.
	02: Command too short	Command data	The command is shorter than the minimum permissible length.	Check the command format and correct the command data.
	03: Elements/data don't match	Command data	The designated number of elements differs from the number of write data items.	Check the number of elements and set data for each element.
	04: Command format error	Command data	An incorrect format was used.	Check the command format and correct the command data.
	05: Header error	Routing table	Either the relay table in the local node or the local network table in the relay node is incorrect.	Set the routing tables correctly.

Main code	Subcode	Check point	Probable cause	Correction
11: Parameter error	01: Area classification missing	Memory area code in command data	The specified word does not exist in the memory area or there is no EM Area.	Check the memory areas and parameter codes in the command and correct the command data.
	02: Access size error	Access size specification in command data	The access size specification is incorrect or an odd word address is specified.	Check the memory areas and access size and correct the access size.
	03: Address range error	Starting address in command data	The start address in command process is beyond the accessible area.	Check the area being processed and set the correct range.
	04: Address range exceeded	Starting address and number of elements in command data	The end address in command process is beyond the accessible area.	Check the area being processed and set the correct range.
		Data link tables	The total number of words is beyond the limit.	Correct the data link tables.
	06: Program missing	Program number in command data	FFFF Hex was not specified.	Specify FFFF Hex.
	09: Relational error	Command data	A large–small relationship in the elements in the command data is incorrect.	Check the command data and correct the relationship between the elements.
		Data link table	A node not set in the common link parameters is set as a refresh parameter.	Correct the data link tables.
	0A: Duplicate data access	I/O access in CPU Unit	Differential monitoring was specified during data tracing or data tracing was specified during differential monitoring.	Abort the current process or wait until it ends before executing the command.
		Data link tables	The same node address is specified more than once.	Correct the data link tables.
	0B: Response too long	Number of elements in command data	The response format is longer than the maximum permissible length.	Check the command format and correct the number of elements.
	0C: Parameter error	Parameters in command data	There is an error in one of the parameter settings.	Check the command data and correct the parameters.
		Data link table file	There is an error in the file.	Check the contents of the file.
20: Read not possible	02: Protected	---	The program area is protected.	Release protection from a Programming Device and then execute the command.
	03: Table missing	Table	A table has not been registered.	Register a table.
			There is an error in the table.	Correct the table.
	04: Data missing	---	The search data does not exist.	---
	05: Program missing	Program number in command data	A non-existing program number has been specified.	Check the program numbers and specify a valid one.
	06: File missing	File name and file device	The file does not exist at the specified file device.	Check the path and file name, and correct them.
	07: Data mismatch	Contents of memory being compared	A data being compared is not the same.	Check memory contents and use the correct data.
---		A file read operation failed.	Check the contents of the file.	

Main code	Subcode	Check point	Probable cause	Correction
21: Write not possible	01: Read-only	---	The specified area is read-only.	If the area is protected using a switch setting, release protection and then execute the command. If the area is permanently read-only, the command cannot be executed.
	02: Protected Cannot write data link table	---	The program area is protected.	Release protection from a Programming Device and then execute the command.
		PLC Setup	Writing is not possible because automatic data link table generation has been specified.	Change the PLC Setup so that the data link tables can be manually written.
	03: Cannot register	Number of files in file device	The file cannot be created because the limit has been exceeded.	Delete any unnecessary files or create more file memory.
		Number of files open	The maximum number of files has already been opened for the system limit.	Close one or more files and then execute the command.
	05: Program missing	Program number in command data	A non-existing program number has been specified.	Check the program numbers and specify a valid one.
	06: File missing	File name	The file does not exist at the specified file device.	Correct the file name and then execute the command.
	07: File name already exists	File name	A file with the same name already exists in the specified file device.	Change the name of the file being written and then execute the command.
08: Cannot change	Contents of memory being changed	The change cannot be made because doing so would create a problem.	---	
22: Not executable in current mode	01: Not possible during execution	---	The mode is incorrect.	Check the mode.
		Data link status	The data link is operating.	Check the status of the data links.
	02: Not possible while running	---	The mode is incorrect.	Check the mode.
		Data link status	The data links are active.	Check the status of the data links.
	03: Wrong PLC mode	---	The PLC is in PROGRAM mode.	Check the modes of the PLC and computer.
	04: Wrong PLC mode	---	The PLC is in DEBUG mode.	Check the modes of the PLC and computer.
	05: Wrong PLC mode	---	The PLC is in MONITOR mode.	Check the modes of the PLC and computer.
	06: Wrong PLC mode	---	The PLC is in RUN mode.	Check the modes of the PLC and computer.
07: Specified node not polling node	---	The specified node is not the polling node.	Check node functioning as the polling node for the network.	
08: Step cannot be executed	---	The mode is incorrect.	Check step status.	
23: No such device	01: File device missing	Unit configuration	The specified memory does not exist as a file device.	Mount memory or format EM as file memory.
	02: Memory missing	---	There is no file memory.	Check the file memory to see if it is mounted.
	03: Clock missing	---	There is no clock.	Check the model.
24: Cannot start/stop	01: Table missing	Data link tables	The data link tables have not been registered or they contain an error.	Set the data link tables.

Main code	Subcode	Check point	Probable cause	Correction
25: Unit error	02: Memory error	Contents of memory being processed	The contents of memory contains an error.	Transfer the correct contents to memory.
	03: I/O setting error	I/O Unit configuration	The registered I/O tables do not agree with the actual I/O configuration.	Correct the I/O tables or the I/O configuration.
	04: Too many I/O points	Number of I/O in registered I/O tables	There are too many I/O points and remote I/O points registered.	Change the registered I/O table so that it is within the limit.
	05: CPU bus error	CPU bus line	An error occurred in data transfer between the CPU and a CPU Bus Unit.	Check Units, Boards, and cables to be sure they are connected correctly and then execute the ERROR CLEAR command.
	06: I/O duplication	Rack numbers, Unit numbers, and I/O addresses in PLC Setup	The same number/address was set more than once.	Check the PLC Setup and correct the numbers/addresses so that each is used only once.
	07: I/O bus error	I/O bus line	An error occurred in data transfer between the CPU and an I/O Unit.	Check Units, Boards, and cables to be sure they are connected correctly and then execute the ERROR CLEAR command.
	09: SYSMAC BUS/2 error	SYSMAC BUS/2 transmission path	An error occurred in data transfer on the SYSMAC BUS/2 line.	Check Units, Boards, and cables to be sure they are connected correctly and then execute the ERROR CLEAR command.
	0A: CPU Bus Unit error	CPU Bus Unit transmission path	An error occurred in data transfer for a CPU Bus Unit.	Check Units, Boards, and cables to be sure they are connected correctly and then execute the ERROR CLEAR command.
	0D: SYSMAC BUS No. duplication	Word settings	The same word is allocated more than once.	Check the I/O tables and correct the allocations.
	0F: Memory error	Status of memory being processed	A memory error has occurred in internal memory, a memory card, or EM file memory.	For internal memory, write the correct data and then execute the command. For a memory card or EM file memory, the file data has been destroyed. Execute the FILE MEMORY FORMAT command. If the problem persists, replace the memory.
10: SYSMAC BUS terminator missing	---	Terminators have not been set.	Set the terminators correctly.	

Main code	Subcode	Check point	Probable cause	Correction
26: Command error	01: No protection	Command protection for program area	The specified area is not protected.	An attempt was made to clear protection on an area that is not protected, i.e., there is no reason to clear protection.
	02: Incorrect password	---	An incorrect password has been specified.	Specify the correct password.
	04: Protected	---	The specified area is protected.	Clear protection from a Programming Device and then execute the command.
		Number of commands being executed	The node receiving the command is already processing 5 commands.	Wait for current processing to end or force the end of a current process and then execute the command.
	05: Service already executing	---	The service is being executed.	Wait for the service to end or force the end of the service and then execute the command.
	06: Service stopped	---	The service is not being executed.	If necessary, start the service.
	07: No execution right	LNK indicator on Unit/Board	The right to execute the service has not been obtained.	The local node is not in the data link. Execute the command from a node that is participating in the data link.
		---	A response was not returned because a buffer error occurred.	Restart the Board. If the problem persists, replace the Board.
	08: Settings not complete	Settings required before execution	The settings required before executing the service have not been made.	Make the required settings.
	09: Necessary items not set	Command data	The required elements have not been set in the command data.	Check the command format and set the required elements in the command data.
0A: Number already defined	Action numbers and transition numbers of program in program area	The specified action/ transition number has already been registered in a previous program.	Check the action/transition numbers to ones that are not being used and then execute the command.	
0B: Error will not clear	Cause of error being cleared	The cause of the error has not been removed.	Remove the cause of the error and then execute ERROR CLEAR.	
30: Access right error	01: No access right	---	The access right is held by another device. (Online editing is being executed from another node or ACCESS RIGHT ACQUIRE or ACCESS RIGHT FORCE ACQUIRE has been executed by another node.)	Wait until the access right is released and then execute the command. ACCESS RIGHT ACQUIRE or ACCESS RIGHT FORCE ACQUIRE can be executed to obtain the access right, but this may adversely affect processing by the node that previously held the access right.
40: Abort	01: Service aborted	---	Service was aborted with ABORT command.	---

APPENDIX B DRIVER NOTES

Appendix B.1 Data Storage

Clock Information

Element	Contents
1	Year (4 for 2004, 12 for 2012)
2	Month
3	Day of Month
4	Hours
5	Minutes
6	Seconds
7	Day of the week (Sunday = 0, Saturday=6)

CPU Cycle Time

Element	Contents
1	Average Cycle Time
2	Maximum Cycle Time
3	Minimum Cycle Time

PLC Mode

Stored Value	PLC Mode
1	STOP
2	MONITOR
3	RUN

CPU Status

Element Number	Contents	Description												
1	1 2 3	<p>CPU Status 1= Stop 2= Standby (waiting for signal from another Device) 3= Run</p> <table border="1"> <thead> <tr> <th>PLC Value</th> <th>Driver Value</th> <th>Meaning</th> </tr> </thead> <tbody> <tr> <td>0x00</td> <td>1</td> <td>Stop</td> </tr> <tr> <td>0x80</td> <td>2</td> <td>Standby</td> </tr> <tr> <td>0x01</td> <td>3</td> <td>Run</td> </tr> </tbody> </table> <p>NOTE: During testing it has been found that the PLC Value corresponds with this book value. Hence the driver stores or sends any other value as it is. User has to do some experiments on it.</p>	PLC Value	Driver Value	Meaning	0x00	1	Stop	0x80	2	Standby	0x01	3	Run
PLC Value	Driver Value	Meaning												
0x00	1	Stop												
0x80	2	Standby												
0x01	3	Run												
2	1 2 3	<p>CPU Mode 1= PROGRAM 2= MONITOR 3= RUN</p>												
3	1/0	1: Memory Error												
4	1/0	1: I/O Bus Error												
5	1/0	1: Duplication Error												
6	1/0	1: Fatal Inner Board Error												
7	1/0	1: I/O Point overflow												
8	1/0	1: I/O Setting Error												

Element Number	Contents	Description
9	1/0	1:Program Error
10	1/0	1:Cycle Time Over
11	0	-
12	1/0	1:FALS Error
13-18	0	-
19	1/0	1:FAL Error
20	Unknown	Reserved for System
21	1/0	1:Interrupt Task Error
22	1/0	1:Basic I/O Unit Error
23	Unknown	Reserved for System
24	1/0	1:PLC Setup Error
25	1/0	1:I/O Verification Error
26	1/0	1:Inner Board Error
27	1/0	1:CPU Bus Unit Error
28	1/0	1:Special I/O Unit Error
29	1/0	1:Sysmac Bus Error
30	1/0	1:Battery Error
31	1/0	1:CPU Bus Unit Setting Error
32	1/0	1:Special I/O Unit-Setting Error
33-34	Unknown	Reserved for System
35-42	0	-
43	1/0	1:Message # 7 Present
44	1/0	1:Message # 6 Present
45	1/0	1:Message # 5 Present
46	1/0	1:Message # 4 Present
47	1/0	1:Message # 3 Present
48	1/0	1:Message # 2 Present
49	1/0	1:Message # 1 Present
50	1/0	1:Message # 0 Present
51	0-65535	Error Code
52-67	A-Z	16 Character Text

Appendix B.2 Driver Stats

In addition to the standard FieldServer operating statistics the driver exposes certain key stats in a Data Array if required. An upstream device can then monitor these stats.

Add the following to the configuration file to activate these stats.

```
// Expose Driver Operating Stats

Data_Arrays
Data_Array_Name      , Data_Format      , Data_Array_Length
fins-stats           , UINT32          , 200
```

Stat Number	Stats	Description
0	FINS_BAD_START	Number of Messages received with bad start byte.
1	FINS_NET	Number of Messages received with bad or unsupported Network Number.
2	FINS_STATION	Number of Messages received with bad or unsupported Node Number.
3	FINS_UNIT	Number of Messages received with bad or unsupported Unit Number.
4	FINS_MRC	Number of Messages received with bad or unsupported Main Request Code.
5	FINS_SRC	Number of Messages received with bad or unsupported Sub Request Code.
6	FINS_SID	Number of Messages received with wrong or Sequence Id.
7	FINS_ECODE	Total number of Messages ignored by PLC due to error.
8	FINS EMC	Latest Main Error code returned by PLC.
9	FINS_ESC	Latest Sub Error code returned by PLC.
10	FINS_EMRC	Main and Sub Request codes for which PLC returned Error Code.
11	FINS_ESRC	
12	FINS_STOR_SP	Number of times Driver ignored messages because of insufficient storage space.
13	FINS_NO_WR_THU	Number of blocked attempts to write data via write-thru operation.

Appendix B.3 Driver Error Messages

Some configuration errors might produce an error every time a poll is generated. This will fill the error buffer quickly and not add any clarity. For this reason, the driver suppresses subsequent similar messages on the System Error Screen. Meaning it is possible for the same error produced by multiple Map Descriptors to produce only one error message on the System Error screen. The driver displays subsequent error messages on the Driver Messages screen.

NOTE: In the actual message, %d has been replaced by an integer, %s by text indicating a data array name or map descriptor name and %x by two hex characters.

Error Message	Description and Action Required
FINS_UDP#1: Err. Not Enough Space for <%d> items. When offset <%d> DA <%s> MD <%s> MRC <%2X> SRC<%2X>	Data array length needs to be increased. ⁹
FINS_UDP#2: Err. MD <%s>. Error Returned by PLC. MRC <%2X> SRC<%2X> Main End Code <%2X> Sub End Code <%2X> See Driver Manual for End Codes detail..	This message shows a request that produced this error at the PLC. Check Appendix A.1 to see the detail for error and action.
FINS_UDP#3: FYI. MRC<%2X> SRC<%2X> Not Supported	This command is not supported by the Driver.
FINS_UDP#4: ERR. Poll to %s Failed	Check Server having this IP. Check cables and connections.
FINS_UDP#11: Err. Station Reqd/Ext <%d/%d>	Response from PLC is not addressed to this Client.
FINS_UDP#12: Err. Mrc-Src Reqd/Ext <%2X-%2X/%2X-%2X>	Response from PLC not for current request.
FINS_UDP#21: Err. Message from PLC is Not a Response MRC <%2X> SRC <%2x> MD <%s>	Message from PLC for shown request is not a response.
FINS_UDP#22: Err. Unknown Device with Parameters... Reqd/Ext dna <%d/%d> node <%d/%d> unit <%d/%d>	Response from PLC ignored because mismatching for any shown parameters.
FINS_UDP#23: Err. Message Sequence Not Matched.Reqd/Ext <%d/%d> MRC <%2X> SRC <%2X> MD <%s>	Response from PLC ignored because of mismatching request-response sequence Id.
FINS_UDP#24: FYI. Bad Start<%2X>	The message was ignored because the first byte was bad.
FINS_UDP#31 : FYI Net_Number set to 1 Node <%s>	The Net_Number parameter is 0 or not specified. The Driver will automatically change it to the default of 1.
FINS_UDP#32 : FYI Udp Port is <%d>	Information about UDP Port number in use.
FINS_UDP#33 : ERR IP Address Required on Node %s	Edit configuration file and specify IP address of physical server on mentioned Node.
FINS_UDP#41: FYI. Write-thru not Possible On MD <%s>	Upstream device tried Write-thru operation on other than IO memory area.
FINS_UDP:#51 FYI. You could have used an Array called <%s> to expose diagnostic info. Read Manual.	Define an array to show stats if needed. See Appendix A .

⁹ Some error messages require that the user correct a problem in the configuration. This is done by editing the configuration CSV file, downloading the modified file and resetting the FieldServer to have the changes take effect.

APPENDIX C TROUBLESHOOTING

Appendix C.1 Connection Tips & Hints

Each transaction must be completed in one UDP message fragment. The maximum length of a UDP fragment is 1500 bytes. Meaning, to read 730 words of PLC memory two MD's must be configured. The one should have a length of 729 and the other a length of 1. The reason is that when the length is set to 729, then 729 words (or 1500 bytes including FINS and UDP header) of data are read and this is the maximum for one message fragment.

Similarly as a Server, the Driver can handle transactions composed of a maximum 1500 bytes (or 729 Words).

Ensure that the IP Address of the PLC provided under IP_Address parameter in configuration is correct

Ensure the Node number of the FieldServer on the network is mentioned under System_Node_Id parameter in configuration file

Ensure that the "Udp_port_number" parameter has the correct value in the configuration file

Omron PLC's respond to remote FINS polls by sending UDP response messages on the ethernet network. The PLC does not use the IP address of the incoming poll to determine the IP address it must respond to. The PLC builds the IP address it will send the response to using

- 1) Its own IP address and the Node ID of the polling device or
- 2) A routing table built using Omron software. To find out more information consult the Omron Manual W343-E1-3, Chapter 3 provides more information.

When the PLC uses its own IP address to build the IP address it will send the response to, then special consideration should be taken if the PLC IP address is Class A or B.

On a Class B network, the PLC uses the 1st two bytes of its own IP address, sets the 3rd byte to zero and sets the 4th byte equal to the polling station's Node_Id.

Appendix C.1.1 Example: Class B Addressing

A FieldServer with IP address=192.168.1.81 and system_node_id=34 polls for data from a PLC with IP address =192.168.2.33 and Subnet mask = 255.255.0.0.

The PLC responds to: 192.168.2.33
255.255.0.0
192.168.x.y

Where x is always set to zero and y is equal to 34 (The PLC obtains the node ID of 34 by inspecting the contents of the poll message.)

Therefore the PLC responds to 192.168.0.34 which is clearly the wrong address and the FieldServer will not see the response.

Appendix C.1.2 Example: Class A Addressing

A FieldServer with IP address=192.168.1.81 and system_node_id=34 polls for data from a PLC with IP address =192.168.2.33 and Subnet mask = 255.255.0.0

The PLC responds to: 192.168.2.33

255.0.0.0

192.x.x.y

Where x is always set to zero and y is equal to 34 (the PLC obtains the node ID of 34 by inspecting the contents of the poll message).

Therefore the PLC responds to 192.0.0.34 which is clearly the wrong address and the FieldServer will not see the response.

Thus, if the PLC is using Class A/B IP addressing then the 3rd (Class B) or the 2nd and 3rd (Class A) bytes of the address must be zero as must the FieldServer's if communications are to work.

There are ways around this problem. The solution requires usage of the Omron PLC routing table. For more help consult with Omron's Tech Support.