

Overview

The Model #4101-28 Infrared Combustible Gas Detector is a ruggedized instrument designed specifically for high-vibration environments like compressor stations. Providing an industry standard analog 4-20 mA interface to connect into customers PLC's, DCS systems, or MSA Safety controllers.

This USA-made, stand-alone gas sensor module is purpose built to meet extreme operating conditions and remote locations. Built with MS Safety's trusted and proven pedigree, and ready to manage your gas risk.

The 4101-28 provides all the built-in features required by instrumentation and safety professionals working with L/CNG environments, including:

- 365-day calibration interval
- UL2075 performance approval
- SIL-2 registered
- CSA, ATEX, IECEx approvals for hazardous locations
- 316 Stainless Steel enclosure
- 3 Wire, current source, 4-20 mA output
- Non-intrusive calibration

Hazardous location approvals for Class 1, Div. 1, Groups B, C, D and Class I, Zone 1, Group IIB+H₂. The 4101-28 is also SIL-2 Certified and meets UL2075 performance requirements.

How It Works

Most combustible gases absorb infrared light energy at defined wavelengths, providing an absorption signature for that gas. The principle of an infrared detector is based upon the absorption of the infrared light at a specific wavelength as it passes through the gas. More light is absorbed as the amount of absorbing gas increases. The detector measures the energy from an infrared light beam at a wavelength that is absorbed by the gas and compares it to the energy emitted by the source. The difference in energy received by the detector indicates the level of gas in the atmosphere.



Features

- Ruggedized design ideal for high-vibration locations like compressor stations
- Analog 0-20mA output
- Single person, non-intrusive calibration

Benefits

- Longest rated calibration cycle for any infrared gas detector - reduced maintenance & cost of ownership
- Industry standard 3 wire analog current source
- Able to calibrate module without declassifying the area

Specifications ***Sensor**

Type: Infrared, Dual Wavelength
Connection: Red = Power, + 24 VDC
 Black = Ground, - 24 VDC
 White = Signal, 0-20mA out
 Green = Shield

Performance

Default Range: 0-100% LEL Methane
Repeatability: +/-1% LEL
Accuracy: 0-100% LEL range
 +/- 5% @ -20 to 30°C (-4 to 86°F)
 +/- 9% above 30°C (86°F)
Zero Drift: +/- 1% full scale per month
 @ 20°C (68°F) ambient
 (max +/- 3% full scale per year)
Sensor Life: Typically >5 years
Heated Sensor: Heated cell to prevent condensation
Response Time: T90<10sec

Operating Range

Ambient Temp Range: -4° to 140°F (-20° to 60°C)
Relative Humidity: 0-95% Non-Condensing

Construction

Dimensions: (H x W x D)
 Inches: 1.5 x 4.5
Weight: 0.6 lb. (0.3 Kg)
Enclosure: 316 Stainless Steel
Enclosure Hazardous Area Classification:
 Explosion proof, Class I, Div. 1, Groups B, C, D
 Class I, Zone 1, Group IIB+H2, IP66, IP65, NEMA 4X, T6
 TA = -20°C to 60°C I12 GD, Ex d IIB+H2

Power

Power consumption: 1 watt maximum
Input voltage: 24VDC nominal: 12-30VDC

Limited Warranty

2 years

Output

Display: None
Signal Output: Analog 4-20 mA Linear, current source
 3-wire Non-Isolated

Approvals

UL-2075
ATEX II 2 G, Ex d IIB+H2 T6 Gb, Ta = -20°C to 60°C
SIL-2 Registered: IEC 61508
CSA: C22.2 Approved
IECEX: Certificate of Conformity



* Specifications subject to change without notice

Operation:

Analog 0-20 mA output: Output begins at 0 mA for 30 seconds upon power up. Then remains at 4 mA for up to 15 minutes during warm up and stabilization. Automatically returns to service once stabilization is complete.

Calibration:

Must use magnetic calibration fitting # 5358-00.

Zero Step = Screw magnetic fitting on sensor housing and keep attached for a minimum of 60 seconds. Output drops to 2.5 mA. Deliver Zero Air at 300 cc/min if necessary. Keep fitting attached.

Span Step = Connect tube and deliver 50% LEL Methane gas at 300 cc/min for a minimum of 3 minutes but no more than 10 minutes. Output remains at 2.5 mA. Remove fitting and output returns to 4 mA for a 5-minute countdown. After 5 minutes, sensor returns to normal operation.

If calibration fails, sensor output drops to 1.4 mA. Power must be cycled to clear condition.

Accessories:**General Accessories**

5311-00 Rainshield
 5100-99-IT-A1-01-00-0-0, Optional IT Transmitter

Calibration Accessories

5358-00 Calibration Head, Magnetic

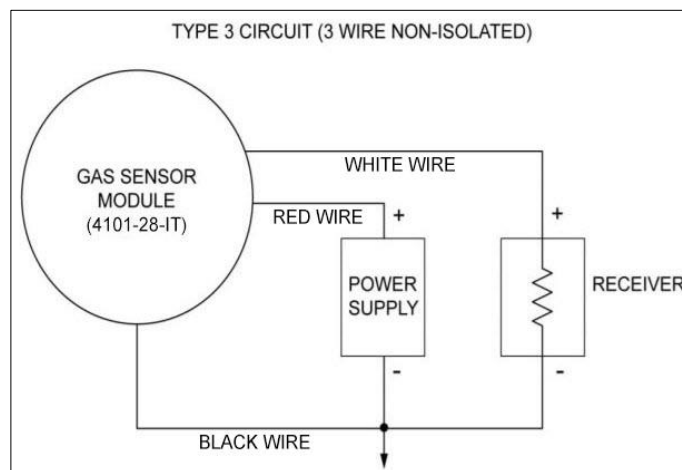
**Calibrators High Capacity**

1250-01 Gas Sensor Calibration Kit, Type A
 1260-02 Combustible Gas 50% LEL Methane, Gas Cylinder Type A
 1260-00 Zero Air Cylinder

Ordering Information:

Model

Gas

4101

-28