

MODEL 3600U

UV FLAME DETECTOR

APPLICABILITY & EFFECTIVITY

Effective for all Model 3600U Detectors manufactured after June 1, 2010.

Instruction Manual Part Number T15012

Rev. 3 August 2010

ABOUT THIS GUIDE

This guide describes the Models 3600U and UB UV Flame Detector and its features and provides instructions on how to install, operate and maintain the detector.

This guide includes the following chapters and appendices:

- **Chapter 1, Introduction**, provides a general overview of the product, principles of operation, and performance considerations.
- **Chapter 2, Installing the Detector**, describes how to install the detector including preparations before installation, wiring and mode settings.
- **Chapter 3, Operating the Detector**, describes how to power-up and test the detector. The chapter also lists safety precautions you should take when operating the detector.
- **Chapter 4, Maintenance and Troubleshooting**, describes basic maintenance procedures, and troubleshooting and support procedures.
- **Appendix A, Technical Specifications**: Lists the detectors technical specifications.
- **Appendix B, Wiring Instructions**, lists the wiring instructions for connecting the detector and also provides examples of typical wiring configurations.
- **Appendix C, RS-485 Communication Network**, provides an overview of the RS-485 communications network.
- **Appendix D, Accessories**, describes the accessories available for the detector.
- **Appendix E, SIL-2 Features**, describes the special conditions to comply with the requirements of EN 61508 for SIL 2 according to TÜV.

ABBREVIATIONS AND ACRONYMS

Abbreviation	Meaning
ATEX	Atmosphere Explosives
AWG	American Wire Gauge
BIT	Built In Test
EMC	Electromagnetic Compatibility
EOL	End of Line
FOV	Field of View
HART	Highway Addressable Remote Transducer-communication protocol
IAD	Immune at Any Distance
IECEx	International Electrotechnical Commission Explosion
IPA	Isopropyl Alcohol
IR	Infrared
JP4	Jet Fuel
Latching	Refers to relays remaining in the ON state even after the ON condition has been removed
LED	Light Emitting Diode
LPG	Liquefied Petroleum Gas
mA	MilliAmps (0.001 amps)
MODBUS	Master-slave messaging structure
N.C.	Normally Closed
N.O.	Normally Open
N/A	Not Applicable
NFPA	National Fire Protection Association
NPT	National Pipe Thread
SIL	Safety Integrity Level
UNC	Unified Coarse Thread
VAC	Volts Alternating Current

TABLE OF CONTENTS

MODEL 3600U..... i

 ABOUT THIS GUIDE..... ii

 ABBREVIATIONS AND ACRONYMS iii

 TABLE OF CONTENTSiv

 LIST OF FIGURESvii

1 INTRODUCTION 1

 1.1 OVERVIEW 1

 1.2 MODEL AND TYPES 2

 1.3 FEATURES AND BENEFITS..... 4

 1.4 PRINCIPLES OF OPERATION..... 4

 1.4.1 DETECTION PRINCIPLES 4

 1.4.2 HEATED OPTICS 5

 1.4.3 HART PROTOCOL 5

 1.4.4 RS-485 MODBUS 5

 1.4.5 PRODUCT CERTIFICATION..... 5

 1.5 PERFORMANCE CONSIDERATIONS..... 6

 1.5.1 DETECTION SENSITIVITY 6

 1.5.2 CONE OF VISION..... 8

 1.5.3 FALSE ALARMS PREVENTION..... 9

 1.5.4 VISUAL INDICATORS 10

 1.5.5 OUTPUT SIGNALS..... 11

 1.5.6 DETECTOR STATUS 12

 1.5.7 AUXILIARY RELAY AS END-OF-LINE RESISTOR 13

 1.6 INTERNAL DETECTOR TESTS 13

 1.6.1 CONTINUOUS FEATURE TEST 13

 1.6.2 BUILT-IN-TEST (BIT)..... 14

2 INSTALLING THE DETECTOR 16

 2.1 GENERAL GUIDELINES 16

 2.2 UNPACKING THE PRODUCT..... 17

 2.2.1 CHECKING THE PRODUCT TYPE..... 17

 2.3 REQUIRED TOOLS 17

 2.4 CERTIFICATION INSTRUCTIONS..... 18

 2.5 INSTALLATION CABLES 19

 2.5.1 CONDUIT INSTALLATION 19

2.6	INSTALLING THE TILT MOUNT (PART NO. 3600-001).....	20
2.6.1	TILT MOUNT SPECIFICATIONS.....	21
2.6.2	TILT MOUNT ASSEMBLY	21
2.7	CONNECTING THE DETECTOR.....	23
2.7.1	VERIFYING THE DETECTOR WIRING	24
2.8	CONFIGURING YOUR DETECTOR	25
2.8.1	ALARM DELAY	25
2.8.2	ADDRESS SET-UP.....	26
2.8.3	FUNCTION SET-UP.....	26
2.8.4	HEATED OPTICS	26
3	OPERATING THE DETECTOR	27
3.1	POWERING UP	27
3.2	SAFETY PRECAUTIONS	28
3.2.1	DEFAULT FUNCTIONS SETTINGS.....	28
3.3	TESTING PROCEDURES	29
3.3.1	AUTOMATIC BIT TEST	29
3.3.2	MANUAL BIT TEST.....	29
3.3.3	TESTING WITH FIRE SIMULATOR MODEL 20/20-311	30
4	MAINTENANCE AND TROUBLESHOOTING.....	31
4.1	MAINTENANCE	31
4.1.1	GENERAL PROCEDURES.....	31
4.1.2	PERIODIC PROCEDURES	31
4.1.3	KEEPING MAINTENANCE RECORDS.....	32

4.2	TROUBLESHOOTING	33
APPENDICES		34
A SPECIFICATIONS		35
A.1	TECHNICAL SPECIFICATIONS	35
A.2	ELECTRICAL SPECIFICATIONS	36
A.3	OUTPUTS	36
A.4	MECHANICAL SPECIFICATIONS	38
A.5	DIMENSIONS	39
A.6	WEIGHT	39
A.7	ENVIRONMENTAL SPECIFICATIONS	39
B WIRING INSTRUCTIONS		41
B.1	GENERAL INSTRUCTIONS FOR ELECTRICAL WIRING	41
B.2	TYPICAL WIRING CONFIGURATIONS	42
C RS-485 COMMUNICATION NETWORK		46
C.1	RS-485 OVERVIEW	46
D ACCESSORIES		47
D.1	LONG RANGE UV/IR FIRE SIMULATOR	47
D.1.1	UNPACKING	48
D.1.2	OPERATING INSTRUCTIONS	48
D.1.3	RANGE	49
D.1.4	CHARGING THE BATTERY	49
D.1.5	TECHNICAL SPECIFICATIONS	50
D.2	TILT MOUNT P/N 3600-001	50
D.3	WEATHER PROTECTION – P/N 777163	51
D.4	LASER DETECTION COVERAGE POINTER – P/N 777166	52
D.5	AIR SHIELD – P/N 777161	52
E SIL-2 FEATURES		53
E.1	3600U/UB FLAME DETECTOR	53
E.1.1	SAFETY RELEVANT PARAMETERS	53
E.1.2	GUIDELINES FOR CONFIGURING, INSTALLING, OPERATING AND SERVICE 53	
LIMITED WARRANTY		55

LIST OF FIGURES

Figure 1: Horizontal Field of View..... 8

Figure 2: Vertical Field of View 8

Figure 3: Indication LED..... 10

Figure 4: Detector with Tilt Mount..... 20

Figure 5: Tilt Mount Assembly..... 21

Figure 6: Tilt Mount Assembly (dimensions in mm and inches) 22

Figure 7: Detector with Cover Removed 23

Figure 8: Wiring Terminals 42

Figure 9: Typical Wiring For 4 Wire Controllers (Using Option 1 or 2 Wiring) 43

Figure 10: 0-20mA Wiring Option 1 (Sink 4-Wire) - Default 44

Figure 11: 0-2mA Wiring Option 1 (Converted to Source 3-Wire)..... 44

Figure 12: 0-20mA Wiring Option 1 (Unisolated Sink 3-Wire) 45

Figure 13: 0-20mA Wiring Option 2 and 3 (Source 3-Wire available with the HART protocol)..... 45

Figure 14: RS-485 Networking 46

Figure 15: UV/IR Long Range Fire Simulator 20/20-311 47

Figure 16: 3600U and UB Detector Target Point 48

Figure 17: Tilt Mount..... 50

Figure 18: Weather Protection 51

Figure 19: Laser Detection Coverage Pointer..... 52

Figure 20: Air Shield 52

LIST OF TABLES

Table 1: Wiring Options 3

Table 2: Detector Versions 3

Table 3: Fuel Sensitivity Ranges..... 7

Table 4: Immunity to False Alarm Sources 9

Table 5: LED Indications 10

Table 6: Available Output Types 11

Table 7: Detector Status 12

Table 8: Output Signals versus Detector State 12

Table 9: Results of a Successful BIT 14

Table 10: Results of an Unsuccessful BIT 14

Table 11: Results of a Successful Manual BIT 15

Table 12: Results of an Unsuccessful Manual BIT 15

Table 13: Tools 17

Table 14: USA Version 21

Table 15: European Version 21

Table 16: Model 3600U and UB Wiring Options 24

Table 17: Functions 26

Table 18: Default Function Values 28

Table 19: Results of Successful Fire Simulator Test 30

Table 20: Troubleshooting Table 33

Table 21: Electrical Specifications 36

Table 22: Contact Ratings 37

Table 23: 20 mA Current Output 37

Table 24: Electromagnetic Compatibility (EMC) 40

Table 25: Maximum DC resistance at 68°F (20°C) for copper wire 41

Table 26: Wiring length in feet (meter) 42

Table 27: Wiring Connections 43

Table 28: Sensitivity Ranges 49

1 INTRODUCTION

➤ **In this chapter...**

<i>Overview</i>	<i>page 1</i>
<i>Model and Types</i>	<i>page 2</i>
<i>Features and Benefits</i>	<i>page 4</i>
<i>Principles of Operation</i>	<i>page 4</i>
<i>Performance Considerations</i>	<i>page 5</i>
<i>Internal Detector Tests</i>	<i>page 13</i>

1.1 OVERVIEW

There are two versions of the 3600 Series UV Flame Detectors: Model 3600U and model 3600UB that also includes a Built in Test (BIT) feature.

The 3600UV Flame Detectors detect hydrocarbon based fuels and gas fires, invisible hydrogen flames and fires from hydride, ammonia, saline and other organic fires.

Note: This type of detector should not be exposed to a UV radiation source, for example; welding, sparks and an electronic arc, as it will result in a false alarm.

All 3600 Series detectors include a heated optical window for improved performance in icing, snow and condensation conditions.

Detection performance can be easily adapted to all environments, applications and requirements, by changing the detector's configuration parameters. Adjusting these parameters, as well as performing other maintenance and monitoring tasks, is possible by means of RS485-based Modbus communication or HART communication (in models with 0-20mA output).

The detector enclosure is ATEX certified EExd flameproof with an integral, segregated, rear, EExe terminal compartment (avoiding exposure of the sensors and electronics to surrounding environment). Hence the combined approval EExde IIB + H₂ T5 (75°C) or T4 (85°C).

The 3600 detectors are designed to operate as a stand-alone unit directly connected to an alarm system, or an automatic fire extinguishing system. The detector can also be a part of a more complex system, where many detectors and other devices are integrated through a common control unit.

1.2 MODEL AND TYPES

The 3600 UV flame detectors are provided in various configurations depending on:

- UV Models
- Wiring options
- Temperature ranges
- Type of cable entry
- Housing type
- Required approval

The configuration detail is included in the product part number on the product label and takes the form: 3600X-XXXXXX, where XXXXXX defines the model according to the above requirements.

To modify the default or pre-ordered configuration and perform maintenance tasks, please refer to the *HART Protocol TM777030* and, the *RS-48 Manual TM 777050* or *TM777060*.

The Part Numbers are defined as:

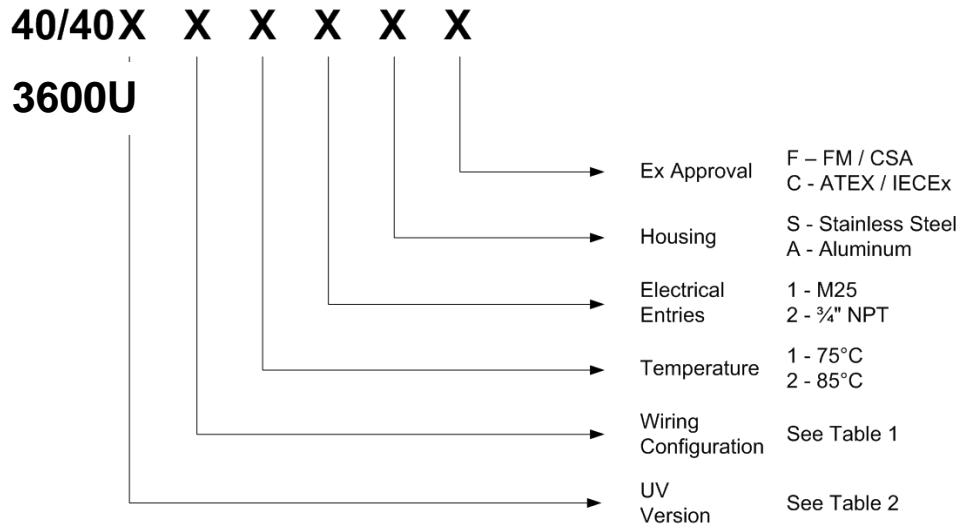

Table 1 describes the wiring options in detail.

Table 1: Wiring Options

Wiring Option	Connections Provided						
1	Power	Manual BIT	Fault Relay N.C.	Alarm Relay N.O.	4-20mA Sink	RS-485	-
2	Power	Manual BIT	Fault Relay N.C.	Alarm Relay N.O, N.C.	4-20mA Source	RS-485	HART
3	Power	Manual BIT	Fault Relay N.O.	Alarm Relay N.O., N.C.	4-20mA Source	RS-485	HART
4	Power	Manual BIT	Fault Relay N.C.	Alarm Relay N.O.	Auxiliary N.O.	RS-485	-
5	Power	Manual BIT	Fault Relay N.O.	Alarm Relay N.O.	Auxiliary N.O.	RS-485	-

Note: Wiring Option 1 is Default. The mA 'Sink' output can be altered to 'source' type with a link between Terminals 1 and 8. No other wiring options can be changed on site.

Table 2: Detector Versions

Detector Version	Description
U	UV without BIT
UB	UV with BIT

For example, product number 3600U-321SC has the following options:

- **Detector Version:** UV, without BIT
- **Wiring Option:** 3 (Power, Manual BIT, RS-485, 0-20mA (Source) with HART Protocol, Fault Relay (N.O.), Alarm Relay (N.O., N.C.))
- **Temperature Range:** 2 (85°C)
- **Cable Entry:** 1 (M25)
- **Housing :** S (Stainless Steel)
- **Approval:** C (ATEX, IECEx)

Note: Check your specific part numbers against the information in *Checking the Product Type* on page 17.

1.3 FEATURES AND BENEFITS

- UV Spectrum design
- High Speed Response: 150msec. response to saturated signal
- Built In Test (BIT): Manual and Automatic (see *Built-In-Test (BIT)* on page 14).
- Heated Window: Prevents effects of icing, snow, condensation.
- Electrical Interface:
 - Dry contact relays
 - Communication network RS-485
 - 0-20mA output
- HART Protocol: Communication protocol (see *HART Protocol* on page 5).
- EExde: Integral junction box for easy wiring.
- SIL-2: TÜV approved.
- Hazardous Area Certification: ATEX, IECEx, FM.

1.4 PRINCIPLES OF OPERATION

This section describes the 3600U and UB principles of operation and includes:

- Detection Principles, page 4
- Heated Optics, page 5
- HART Protocol, page 5
- RS-485 Modbus, page 5
- Product Certification, page 5

1.4.1 DETECTION PRINCIPLES

The Model 3600U and UB Flame Detector is an electronic device designed to sense the occurrence of fire and flames and subsequently activate an alarm or an extinguishing system directly or through a control circuit.

The UV Flame Detector is a single spectrum optical detector sensitive to the UV radiation spectrum that is present in fires. The detector monitors the protected volume, by measuring the radiation intensity in it, within the frequency range of the electromagnetic spectrum, namely the Ultra-Violet (UV).

The detector senses one channel in which appropriate detection pulses are registered, and further analyzed for frequency, intensity and duration.

- Sensing Element

The UV sensor is sensitive to radiation over the range of 0.185-0.260 micron. The UV channel incorporates a special logic circuit that eliminates false alarms caused by solar radiation and other non-fire UV sources. Furthermore, the UV channel's sensitivity is stabilized over the working temperature range.

- Detection Levels

Detection of radiation in the UV channel having an intensity that exceeds the detector's preset warning level results in a:

- Warning signal
- Alarm signal

1.4.2 HEATED OPTICS

The 3600 Flame Detectors use heated optics. The heater increases the temperature of the optical surface by 5°F - 8°F (~3°C - 5°C) above the ambient temperature to improve performance in icing, condensation and snow conditions.

The heated optics can be set to one of the following:

- Not operated
- On continuously
- Automatic (Auto), per temperature change (default): you can define the start temperature below which the window is heated. (The default is 41°F (5°C).) This temperature can be defined between 32°F (0°C) to 122°F (50°C). The heating stops when the temperature is 27°F (15°C) above the start temperature.

For more information, see *Configuring your Detector* on page 25.

1.4.3 HART PROTOCOL

The 3600 Flame Detectors use the HART Protocol.

HART Communication is a bi-directional industrial field communication protocol used to communicate between intelligent field instruments and host systems. HART is the global standard for smart process instrumentation and the majority of smart field devices installed in plants worldwide are HART-enabled. HART is available in wiring options 2 and 3, see Table 1.

HART technology is easy to use and very reliable.

Through the HART connection, you are able to perform:

- Detector set-up
- Detector troubleshooting
- Detector health and status

For more details, refer to the *HART Manual TM 777030*.

1.4.4 RS-485 MODBUS

For more advanced communications, the 3600 detector has an RS 485 Modbus-compatible output that provides data communication from a network (up to 247 detectors) to a host computer or universal controller for central monitoring. This feature allows for reduced installation costs, easy maintenance and local or remote diagnostic tools.

1.4.5 PRODUCT CERTIFICATION

The 3600U/UB Flame Detectors have the following certifications:

- ATEX, IECEx page 6
- SIL-2 Approved (TÜV), page 6

1.4.5.1 ATEX, IECEX

The 3600U/UB Optical Flame Detector is certified to:

- ATEX Ex II 2 GD per SIRA 07ATEX 1149 and IECEx SIR. 07.0085.
- EExde IIB + H₂.
- T5 Ambient Temp. -55°C to +75°C.
- T4 Ambient Temp. -55°C to +85°C.

This product is suitable to use in hazardous zones 1 and 2 with IIB + H₂ gas group vapors present.

1.4.5.2 SIL-2 APPROVED (TÜV)

The 3600U/UB Optical Flame Detector is certified to SIL-2 requirement per IEC 61508.4, Chapter 3.5.12.

The alert condition according to SIL-2 can be implemented by:

- Alert signal via 0-20mA current loop.
- or
- Alert signal via alarm relay and fault relay.
- For more details and guidelines for configuring, installing, operating and service – see *SIL-2 Features* on page 53 and TÜV Report No. 968/EZ348.00/009.

1.5 PERFORMANCE CONSIDERATIONS

This section describes performance aspects and includes:

- Detection Sensitivity, page 6
- Cone of Vision, page 8
- False Alarms Prevention, page 9
- Visual Indicators, page 10
- Output Signals, page 11
- Detector Status, page 12
- Auxiliary Relay as End-of-Line Resistor, page 13

1.5.1 DETECTION SENSITIVITY

Detection sensitivity is the maximum distance at which the detector reliably detects a specific size of fire and typical type of fuel (standard fire).

1.5.1.1 STANDARD FIRE

Defined as a 1ft² / 0.1m² n-heptane pan fire, with maximum wind speed of 6.5 ft./sec (2 m/sec).

1.5.1.2 SENSITIVITY RANGES

The detector has two response levels.

- WARNING (Pre-alarm)
- ALARM

The detection distance for the Alarm level is 50 ft. (15m) from the standard fire.

The detection distance, for the WARNING level, is approximately 10% higher than the ALARM distance.

For some typical ambient conditions the Zeta parameter as defined in NFPA 72 for the detector is 0.005 (1/meter).

Note: Zeta parameters may vary significantly with changes in temperature, air pressure, humidity, visibility conditions, and so on.

1.5.1.3 OTHER FUELS

- The detector reacts to other types of fire as follows:
- The baseline fire refers to n-heptane 1ft² (0.1m²) pan fire and is defined as 100% sensitivity.
- For fuel fires – standard pan fire size:1 ft² (0.1 m²)
- For gas flames - 20 inch (0.5m) high, 8 inch (0.2m) width plume fire.
- Maximum Response Time: 10 sec

Table 3: Fuel Sensitivity Ranges

Type Of Fuel	Max. Distance (ft./m)
	3600U and UB
Gasoline	50/15
N-Heptane	50/15
JP4	37/11
Kerosene	37/11
Diesel Fuel	37/11
Alcohol 95%	37/11
IPA	37/11
Methanol	37/11
Methane	40/12
LPG	40/12
Paper	20/6
Polypropylene	18/5
Hydrogen	33/10

1.5.2 CONE OF VISION

- Horizontal: 100°

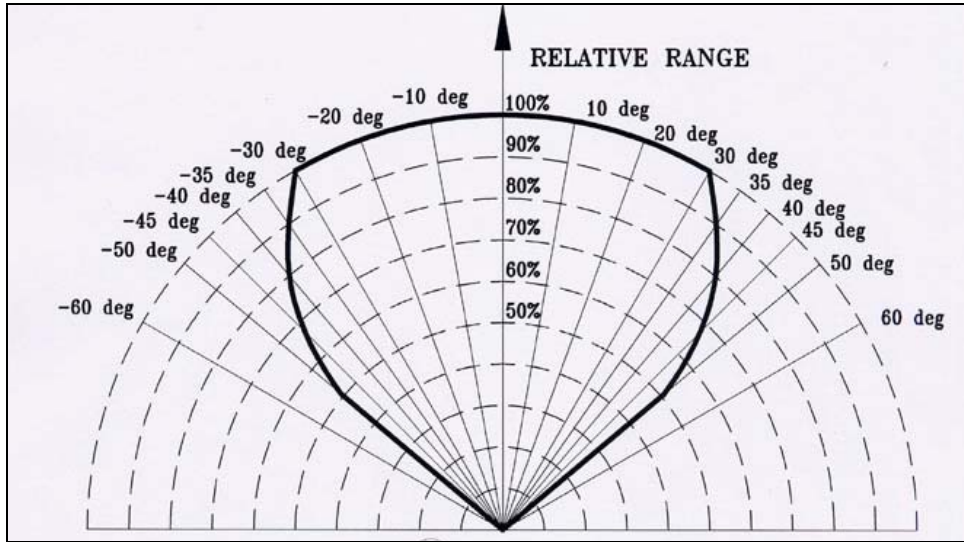

Figure 1: Horizontal Field of View

- Vertical: +50° (down) , -45° (up)

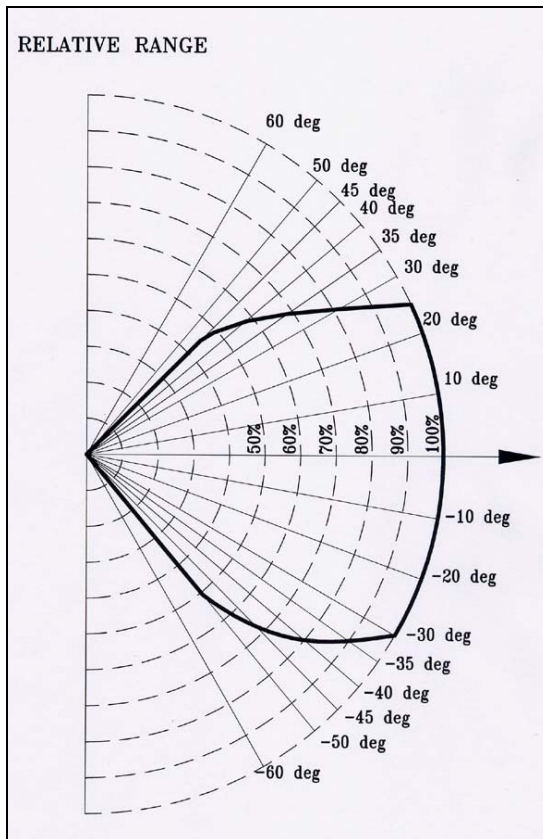

Figure 2: Vertical Field of View

1.5.3 FALSE ALARMS PREVENTION

To prevent false alarms, the detector will not alarm or react to the radiation sources specified in Table 4.

Table 4: Immunity to False Alarm Sources

Radiation Source	Immunity Distance ft.(m)
Indirect or reflected sunlight	IAD
Vehicle headlights (low beam) conforming to MS53023-1	IAD
Incandescent frosted glass light, 300 W	IAD
Fluorescent light with white enamel reflector, standard office or shop, 70 W (or two 35 W)	IAD
Electric arc [12mm (¹⁵ / ₃₂ " gap at 4000 V alternating current, 60 Hz]	IAD
Ambient light extremes (darkness to bright light with snow, water, rain, desert glare and fog)	IAD
Bright colored clothing, including red and safety orange.	IAD
Blue-green dome light conforming to M251073-1	IAD
Flashlight (MX 991/U)	IAD
Radiation heater, 3000 W	IAD
Radiation heater, 1000 W with fan	IAD
Lit cigar	5 (1.5)
Lit cigarette	5 (1.5)
Match, wood, stick including flare up	16.5 (5)

Notes:

- IAD = Immune at Any Distance
- All sources are chopped from 0 to 20 Hz.

1.5.4 VISUAL INDICATORS

One 3-color LED indicator is located inside the detector window, as shown in Figure 3. The detector statuses are listed in Table 5.

Table 5: LED Indications

Detector Status	LED color	LED mode
Fault, BIT Fault	Yellow	4 Hz - flashing
Normal	Green	1 Hz - flashing
Warning	Red	2 Hz - flashing
Alarm	Red	Steady

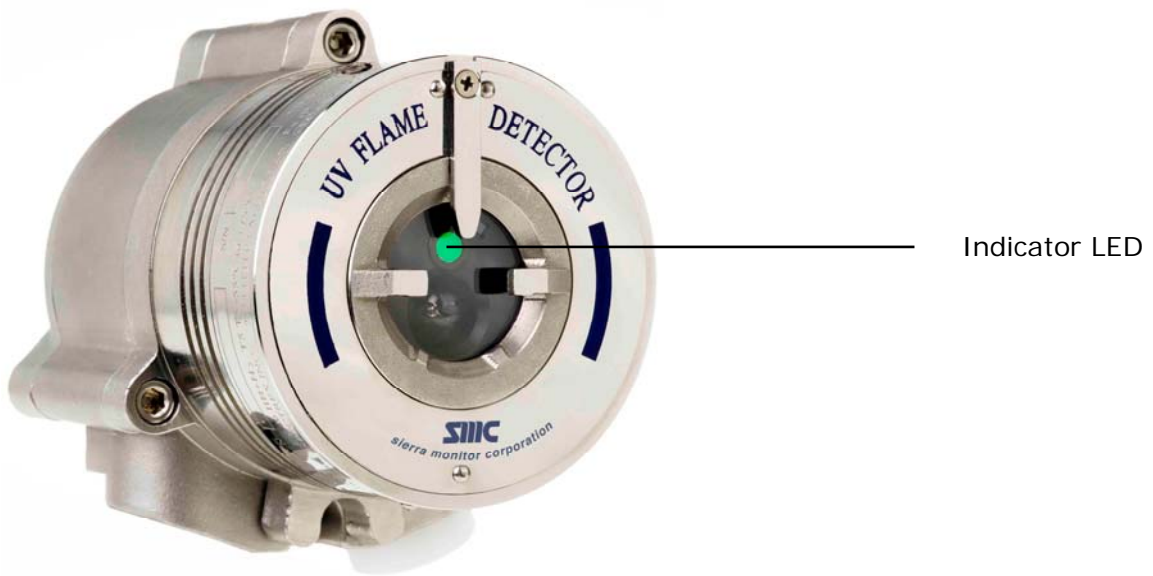

Figure 3: Indication LED

1.5.5 OUTPUT SIGNALS

Outputs are available according to the default configuration or the wiring options selected for the Detector. Determine the outputs for your model according to Table 6.

The detector incorporates several types of output suitable to different control systems:

- 0-20mA (stepped) with HART
- Relays (Alarm, Fault, Auxiliary)
- RS-485 Modbus

Table 6: Available Output Types

Output Type	Wiring Version	Detector Status
Alarm relay	3600U , UB – Options 1XXXX, 4XXXX, 5XXXX	The relay is N.C.
	3600U and UB – Options 2XXXX, 3XXXX	The relay is N.O. and N.C.
Auxiliary relay	3600U and UB – Options 4XXXX and 5XXXX	The relay is N.O.
Fault relay	3600U and UB – Options 1XXXX, 2XXXX, 4XXXX	The relay is N.C. energized
	3600U and UB – Options 3XXXX, 5XXXX	The relay is N.O. energized
0-20mA current output	3600U and UB – Option 1XXXX	SINK Option, (can be changed to Source – see Figure 10, Figure 11 and Figure 12)
	3600U and UB – Options 2XXXX and 3XXXX	SOURCE Option with HART protocol
RS-485	All versions	Modbus Protocol

1.5.6 DETECTOR STATUS

The possible detector function statuses are listed in Table 8. A more detailed fault analysis can be seen via HART or RS485.

Table 7: Detector Status

Status	Description
Normal	Normal operation.
BIT	Built-In-Test being performed.
Warning	Fire detected - changed to Warning (pre-alarm state).
Alarm	Fire detected - changed to Fire Alarm state.
Latched Alarm (Optional)	The alarm outputs remain latched on following detection of a fire that has already been extinguished.
BIT Fault	A fault is detected during BIT sequence or other electric failure. The detector will continue to detect for fire
Fault	A fault is detected when the power supply is too low or due to a software fault or electrical failure. The detector will NOT detect fire in this condition

In each state, the detector activates different outputs, as specified in Table 8.

Table 8: Output Signals versus Detector State

Detector State	LED Indicator	LED Mode	Alarm Relay	Auxiliary Relay	Fault Relay	mA output
Normal	Green	1Hz	Off	Off	On	4mA
Warning	Red	2Hz	Off	On ⁽⁴⁾	On	16mA
Alarm ⁽¹⁾	Red	Constant	On	On	On	20mA
Latch ⁽²⁾	Red	Constant	On	Off	On	20mA
				On ⁽⁴⁾	On	20mA
BIT Fault ⁽³⁾	Yellow	4Hz	Off	Off	Off	2mA
Warning at BIT Fault	Red	2Hz	Off	On ⁽⁴⁾	Off	16mA
Alarm at BIT Fault	Red	Constant	On	On	Off	20mA
Fault	Yellow	4Hz	Off	Off	Off	0mA

Notes:

- 1 The alarm outputs are activated while alarm conditions exist and will stop approximately 5 seconds after the fire is no longer detected.
- 2 The Alarm state can be optionally latched via programmed function. (Default is non-latching).
- 3 The detector will remain in BIT Fault state until it has passed a successful BIT.
- 4 The Auxiliary Relay can be activated at the Warning level or Alarm level, depending on programmed function.
- 5 The outputs depend on the wiring options.

1.5.6.1 OPTIONAL LATCHING

Alarms are set as non-latching by default. However, the detector includes a latched alarm output capability, which operates according to the programmed function.

If selected, upon detection of a fire, the detection signal is latched until a manual reset is performed (disconnecting the power supply or performing a manual BIT (see *Manual BIT* on page 15).

Latching affects the Alarm Relay, 0-20mA output, the Alarm LED (the Auxiliary Relay will be latched only when the programmable function Auxiliary Relay is set to YES).

Notes:

- The Auxiliary Relay is available only in Models with suffix – 4XXXX and 5XXXX
- The 0-20mA is available only in Models with suffix – 1XXXX, 2XXXX and 3XXXX

1.5.7 AUXILIARY RELAY AS END-OF-LINE RESISTOR

The Auxiliary Relay can be used as End-of-Line (EOL) resistance in Models with suffix - 4XXXX, and 5XXXX only. In this case, the Auxiliary Relay is active as long as the detector is not in Fault state.

1.6 INTERNAL DETECTOR TESTS

The detector performs two types of self tests:

- Continuous Feature Test, page 13
- Built-In-Test (BIT), page 14

1.6.1 CONTINUOUS FEATURE TEST

During normal operation, the detector tests itself continuously and indicates a fault if a failure is found. This type of test complies with SIL-2 requirements.

The detector continuously tests:

- Input voltage level
- All internal regulator voltage level
- Voltage level status of sensor and sensor circuitry for noise or disconnection in the electronic circuitry.
- 0-20mA level output
- Relays and heater operation
- Processor Watch dog
- Software
- Memory
- Oscillator frequency

Response to Fault Indication

If a failure is found, the detector indicates by:

- Fault relay:
 - Opens in wiring option 1, 2, and 4
 - Closes in wiring options 3 and 5
- 0-20mA: indicates Fault (0mA or 2mA) in wiring options 1, 2 and 3

- LED – Yellow flashes (4 Hz)

Correcting the Fault

The fault indications remain until the detector’s power is removed. The fault indications return if the fault is still found when power is restored.

1.6.2 BUILT-IN-TEST (BIT)

The detector’s Built-In-Test (BIT) also checks the following:

- Electronics circuitry
- Sensors
- Window cleanliness

The detector can be set to perform the BIT in the following modes:

- Automatically and manually
- Manually only

Note: In Manual BIT, the outputs may also be tested and Control System ‘inhibit’ should be applied if this could initiate other systems.

1.6.2.1 HOW THE BIT OPERATES

- The detector's status remains unchanged if the result of a BIT is the same as the current status (NORMAL or BIT Fault)
- the detectors’ status is changed (from Normal to BIT Fault or vice versa) if the BIT differs from the current status

Note: In ‘BIT Fault’ status the detector can continue to detect a fire.

1.6.2.2 AUTOMATIC BIT

The detector automatically performs a BIT every 15 minutes. A successful BIT sequence does not activate any indicator.

The results of a successful and unsuccessful BIT are listed in Table 9 and Table 10.

Table 9: Results of a Successful BIT

Output	Result
Fault relay	<ul style="list-style-type: none"> • Wiring options 1, 2 and 4: remains CLOSED • Wiring options 3 and 5: remains OPEN
0-20mA output	Wiring options 1, 2 and 3: Normal (4mA)
Power LED	Green, Flashing, 1 Hz On (Normal)

Table 10: Results of an Unsuccessful BIT

Output	Result
Fault relay	<ul style="list-style-type: none"> • Wiring options 1, 2 and 4: changes to Open • Wiring options 3 and 5: changes to Closed
0-20mA output	Wiring options 1, 2 and 3: BIT Fault (2mA)
Power LED	Yellow, Flashing, (4 Hz)
BIT procedure	Performed every 1 minute

1.6.2.3 MANUAL BIT

The BIT is manually initiated by momentarily connecting Terminal 3 with Terminal 2 (or a switch across these terminals in the safe area).

If the BIT is unsuccessful, all outputs will function as described for Automatic BIT, but the BIT is now automatically executed every 1 minute. This continues until a successful BIT occurs, when the detector will resume normal operation.

The results of a successful and unsuccessful Manual BIT are listed in Table 11 and Table 12.

Table 11: Results of a Successful Manual BIT

Output	Result
FAULT relay	<ul style="list-style-type: none"> Wiring options 1, 2, and 4: remains CLOSED (Normal). Wiring options 3 and 5: remains OPEN (Normal)
ALARM relay	Activated for 3 sec (only when the function Alarm BIT is set to YES).
AUXILIARY relay	For wiring options 4 and 5: is activated for 3 sec (only when the function Auxiliary BIT is set to YES)
0-20mA output	Wiring options 1, 2 and 3: <ul style="list-style-type: none"> Initiates 20mA (only when the function Alarm BIT is set to YES) Initiates 16mA when the function Auxiliary BIT is set to YES and the function Alarm BIT is set to NO.
POWER LED	Green, Flashing, 1 Hz

Table 12: Results of an Unsuccessful Manual BIT

Output	Result
FAULT relay	<ul style="list-style-type: none"> Wiring options 1, 2 and 4: changes to OPEN Wiring options 3 and 5: changes to CLOSED
0-20mA output	Wiring options 1, 2 and 3: Indicates BIT FAULT (2mA)
POWER LED	Yellow, Flashing, 4 Hz

1.6.2.4 MANUAL BIT ONLY SELECTED

The BIT is initiated manually by momentarily connecting Terminal Number 3 with Terminal Number 2 or a switch across these terminals in the safe area.

2 INSTALLING THE DETECTOR

➤ **In this chapter...**

<i>General Guidelines</i>	<i>page 16</i>
<i>Unpacking the Product</i>	<i>page 17</i>
<i>Required Tools</i>	<i>page 17</i>
<i>Certification Instructions</i>	<i>page 18</i>
<i>Installation Cables</i>	<i>page 19</i>
<i>Installing the Tilt Mount (part no. 3600-001)</i>	<i>page 20</i>
<i>Connecting the Detector</i>	<i>page 23</i>
<i>Configuring your Detector</i>	<i>page 25</i>

This chapter provides basic guidelines for installing the detector. It does not attempt to cover all of the standard practices and codes of installation. Rather, it emphasizes specific points of consideration and provides some general rules for qualified personnel. Wherever applicable, special safety precautions are stressed.

2.1 GENERAL GUIDELINES

To ensure optimal performance and an efficient installation, consider the following guidelines:

- **Sensitivity:** To determine the level of sensitivity, consider the following:
 - Size of fire at the required distance to be detected
 - Type of flammable materials
- **Wiring:**
 - The wires gauge must be designed according to the distance from the detector to the controller and according to the number of the detectors on the same power line. See Appendix B.
 - In order to fully comply with EMC directive, the cable to the detector must be shielded and the detector must be grounded.
- **Spacing and Location:** The number of detectors and their locations in the protected area are determined by:
 - Size of the protected area
 - Sensitivity of the detectors
 - Obstructed lines of sight
 - Cone of view of the detectors
- **Environment:**
 - Dust, snow or rain can reduce the detectors sensitivity and require more maintenance activities.

- The presence of high intensity flickering IR sources may affect sensitivity.
- **Aiming the Detector:**
 - The detector should be aimed toward the center of the detection zone and have a completely unobstructed view of the protected area.
 - Whenever possible, the detector face should be tilted down at a 45° angle to maximize coverage and prevent accumulation of dust and dirt.
 - Do not start an installation unless all conceivable considerations regarding detection location have been taken into account.

Installation should comply with **NFPA 72E or any other local and International regulations and standards**, as applicable to flame detectors and installation of Ex approved products.

2.2 UNPACKING THE PRODUCT

Upon receipt of your detector, check and record the following:

- 1 Verify the appropriate Purchase Order.
Record the Part Number (P/N) and Serial Number of the detectors, and the installation date in an appropriate Log-book.
- 2 Open the package before installation and visually inspect the detector.
- 3 Verify that all components required for the detector installation are readily available before beginning the installation. If the installation is not completed in a single session, secure and seal the detectors and conduits / cable entries.

2.2.1 CHECKING THE PRODUCT TYPE

Check that your product has the configuration / options that you ordered. Check the detailed part number on the label and compare this information with the descriptions contained in *Model and Types* on page 2.

2.3 REQUIRED TOOLS

The detector can be installed using general-purpose common tools and equipment. Table 13 lists the specific tools required to install the detector.

Table 13: Tools

Tool	Function
Hex Key 1/4 inch	Mount the detector on the tilt mount
Hex Key 3/16 inch	Open and close detector cover (for wiring)
Flat Screw Driver 4 mm	Connect ground terminal
Flat Screw Driver 2.5 mm	Connect wires to the terminal blocks

For wiring, use color-coded conductors or suitable wire markings or labels. 12 to 20 AWG (0.5 mm² to 3.5 mm²) wires may be used for site wiring. The selection of wire gauge should be based on the number of detectors used on the same line and the distance from the control unit, in compliance with specifications (see *General Instructions for Electrical Wiring* on page 41).

2.4 CERTIFICATION INSTRUCTIONS



Warning: Do not open the detector, even when isolated, when flammable atmosphere present.

Use the following certification instructions:

- The cable entry point may exceed 167°F (75°C). Suitable precautions should be taken when selecting the cable.
- The equipment may be used with flammable gases and vapors with apparatus groups IIA and IIB + H₂:
 - T5 in the ambient temperature range: -67°F (-55°C) to +167°F (+75°C).
 - T4 in the ambient temperature range: -67°F (-55°C) to +185°F (+85°C).
- Installation shall be carried out by suitably trained personnel in accordance with the applicable code of practice such as EN 60079-14:1997.
- Inspection and maintenance of this equipment shall be carried out by suitably trained personnel in accordance with the applicable code of practice such as EN 60079-17.
- Repair of this equipment shall be carried out by suitably trained personnel in accordance with the applicable code of practice such as EN 60079-19.
- The certification of this equipment relies upon the following materials used in its construction:
 - **Enclosure:** 316L Stainless Steel or Aluminum
 - **Window:** Sapphire Glass
- If the equipment is likely to come into contact with aggressive substances, then it is the responsibility of the user to take suitable precautions that prevent it from being adversely affected, thus ensuring that the type of protection provided by the equipment is not compromised:
 - Aggressive substances: acidic liquids or gases that may attack metals, or solvents that may affect polymeric materials
 - Suitable precautions: regular checks as part of routine inspections or establishing from the material's data sheets that it is resistant to specific chemicals.

2.5 INSTALLATION CABLES

Follow the following guideline for the cable installation:

- All cables to the detector must be well shielded in order to comply with EMC requirement (see *Technical Specifications* on page 50).
- Ground the detector to the nearest ground point (not more than 3m from the detector location).
- Install the detector with the cable entries placed downwards.

2.5.1 CONDUIT INSTALLATION

The conduit used for the cabling must comply with the following:

- To avoid water condensation water in the detector, install the detector with the conduits placed downward, that include drain holes.
- When using the optional tilt mount, use flexible conduits for the last portion connecting to the detector.
- For installations in atmospheres as defined in group B of the NFPA 72E, seal the conduits inlets.
- When pulling the cables through the conduits, ensure that they are not tangled or stressed. Extend the cables about 30 cm. (12 in.) beyond the detector location to accommodate wiring after installation.
- After the conductor cables have been pulled through the conduits, perform a continuity test.

2.6 INSTALLING THE TILT MOUNT (PART NO. 3600-001)

The Tilt Mount enables the detector to be rotated up to 60° in all directions.

Figure 4 shows the Detector mounted on the Tilt Mount.

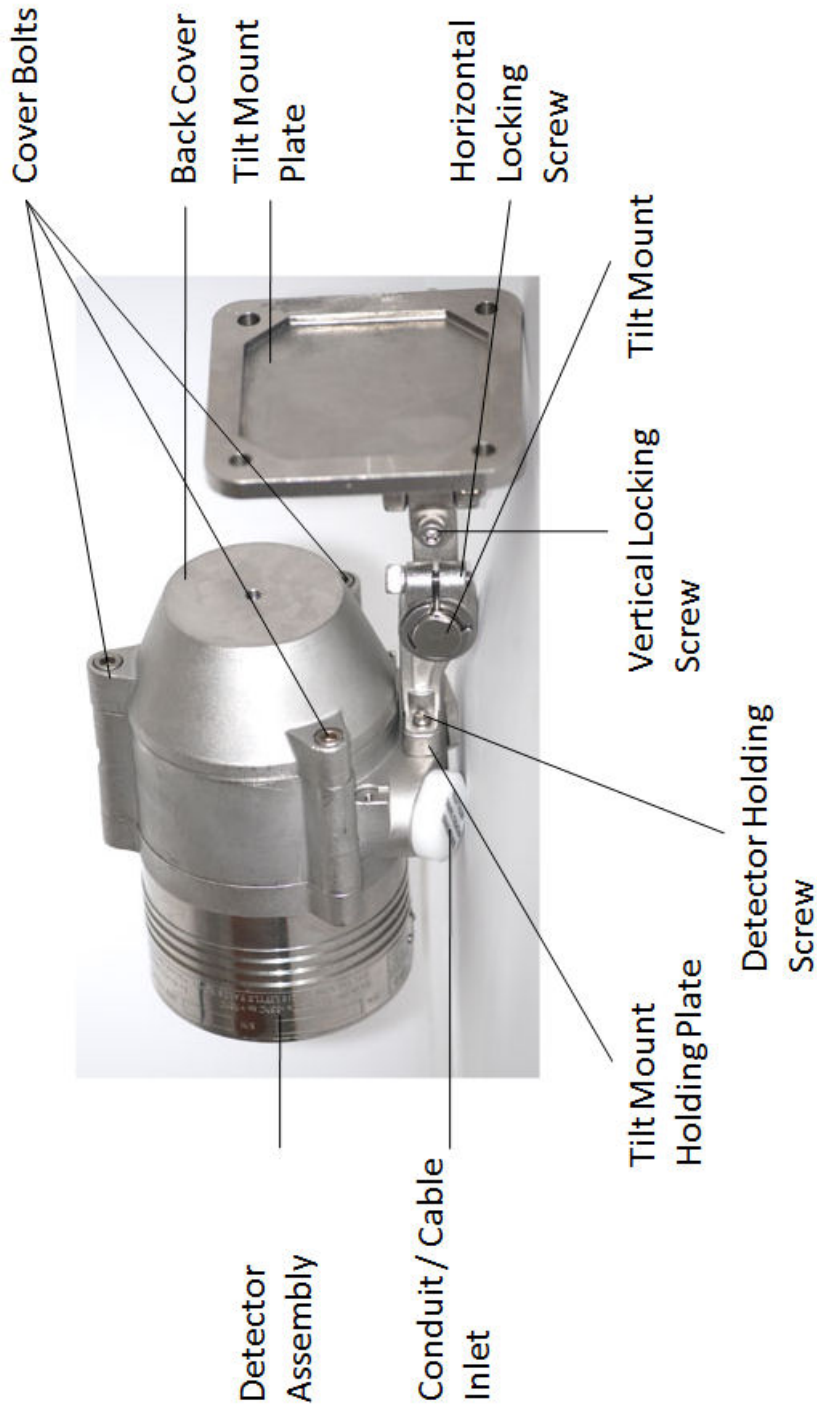

Figure 4: Detector with Tilt Mount

2.6.1 TILT MOUNT SPECIFICATIONS

Table 14: USA Version

Item	Qty	Type	Location
Tilt Mount	1	3600-001	
Screw	4	1/4" 20 UNC x 3/4"	Detector – Holding plate
Spring Washer	4	No. 1/4"	Detector - Holding plate

Table 15: European Version

Item	Qty	Type	Location
Tilt Mount	1	3600-001	
Screw	4	M6 x 1 x 20 mm	Detector – Holding plate
Spring Washer	4	M6	Detector - Holding plate

2.6.2 TILT MOUNT ASSEMBLY

Figure 5 shows the Tilt Mount Assembly.

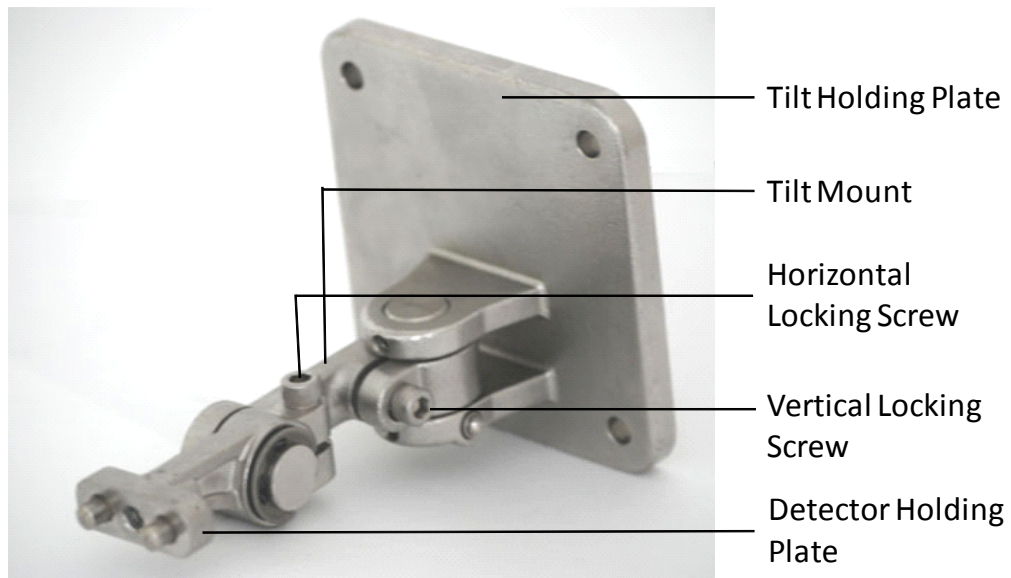

Figure 5: Tilt Mount Assembly

Figure 6 shows the Tilt Mount Assembly with dimension in both millimeters and inches.

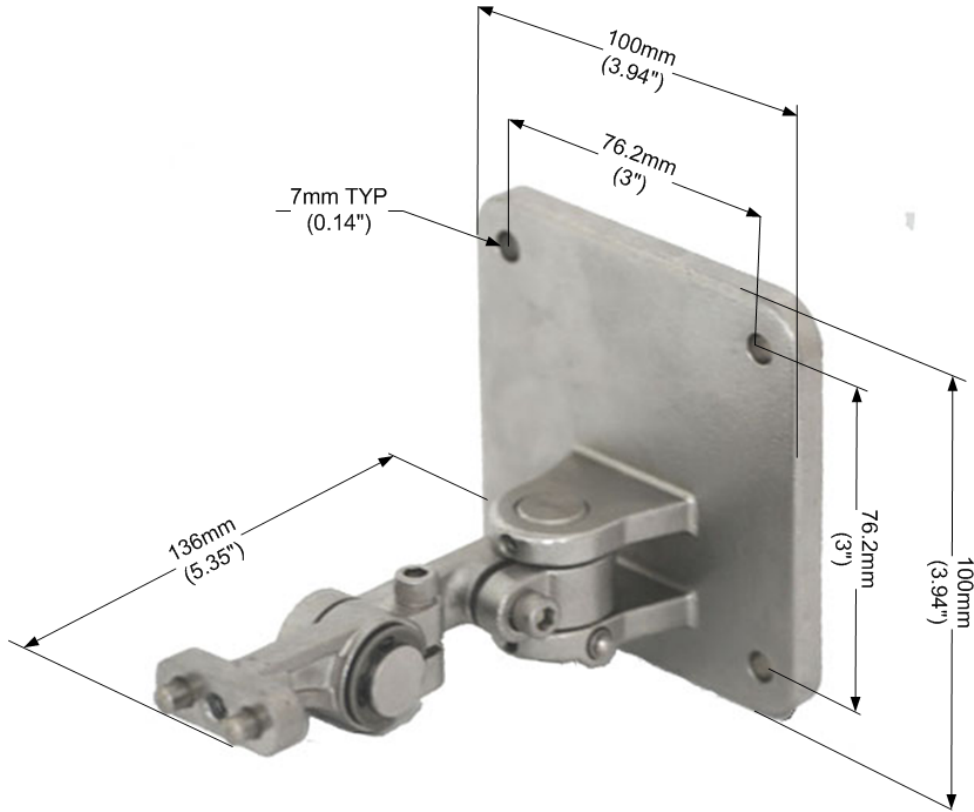

Figure 6: Tilt Mount Assembly (dimensions in mm and inches)

➤ **To install the Tilt Mount and Detector:**

- 1 Place the tilt mount in its designated location and secure it with four (4) fasteners through four (4) holes 7 mm in diameter. Use the four (4) screws and spring washers according to the kit (see Table 14 and Table 15).

Note: Removing the detector for maintenance purpose does not require the Tilt Mount to be removed).

- 2 Unpack the detector.
- 3 Place the detector, with its conduit/cable entries pointing downwards, on the holding plate of the Tilt Mount. Secure the detector with $\frac{5}{16}$ " 18 UNC x 1" screw to the Tilt Mount.
- 4 Release the Horizontal and Vertical Locking Screws using $\frac{3}{16}$ " Hex Key such that the detector can be rotated. Point the detector towards the protected area and make certain that the view of the area is unobstructed. Secure the detector in that position by tightening the locking screws on the tilt mount. (Make sure the detector is in the correct position.).

The detector is now correctly located, aligned and ready to be connected to the system

2.7 CONNECTING THE DETECTOR

This section describes how to connect the electric cabling to the detector (Figure 7).

➤ **To connect the detector to the electrical cables**

- 1 Disconnect the power.
- 2 Remove the back cover of the detector by removing four (4) socket head-screws in the cover bolts. The terminal chamber is now revealed.
- 3 Remove the protective plug mounted on the Detector Conduit/Cable entry; pull the wires through the Detector Inlet.
- 4 Use a 3/4" – 14 NPT explosion-proof conduit connection or M25x1.5 flameproof gland to assemble the cable / conduit to the detector.

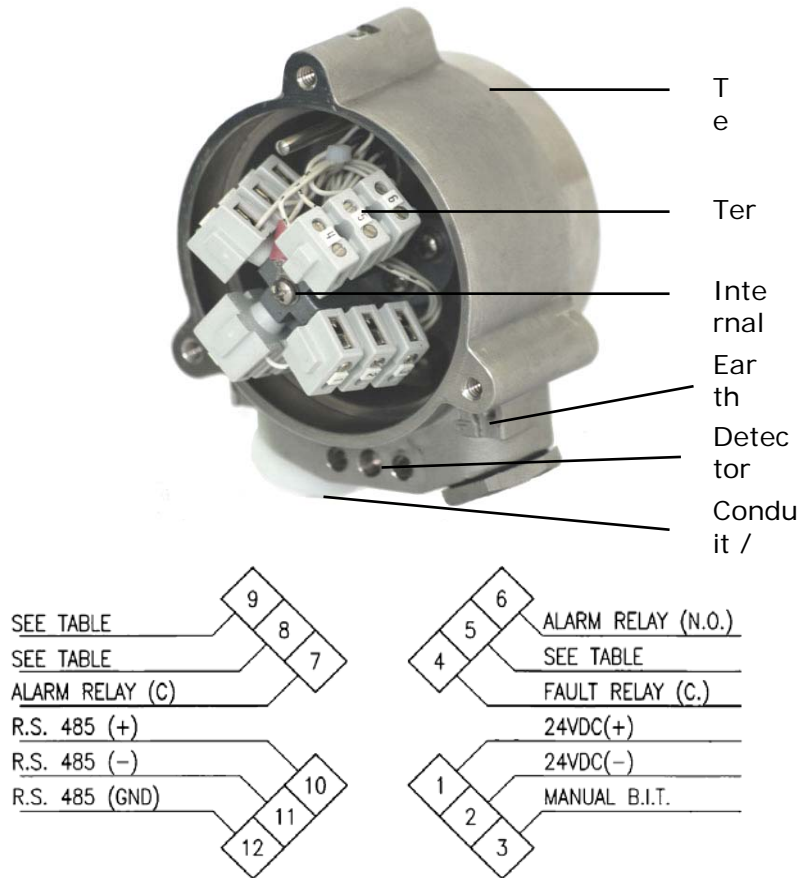

Figure 7: Detector with Cover Removed

- 5 Connect the wires to the required terminals on the Terminal Board according to the wiring diagram (Figure 7) and Table 16.
- 6 Connect the grounding (earth) wire to the ground (earth) screw outside the detector (Earth Terminal). The detector must be well grounded to earth ground.
- 7 Verify the wiring. Improper wiring may damage the detector.
- 8 Check the wires for secure mechanical connection and press them neatly against the terminal to prevent them from interfering while closing the back cover (Figure 7).

- 9 Place and secure the detector's back cover by screwing the four (4) socket-head-screws in the Cover Bolts (Figure 4).

2.7.1 VERIFYING THE DETECTOR WIRING

The detector has five output wiring options within the EExde integral terminal section of the enclosure. There are 12 terminals labeled 1-12.

Table 16 describes the function of each terminal for all the wiring options.

Table 16: Model 3600U and UB Wiring Options

Wire Terminal No.	Option 1 Default	Option 2	Option 3	Option 4	Option 5
1	+24 VDC	+24 VDC	+24 VDC	+24 VDC	+24 VDC
2	0 VDC	0 VDC	0 VDC	0 VDC	0 VDC
3	Manual BIT	Manual BIT	Manual BIT	Manual BIT	Manual BIT
4	Fault Relay N.C.	Fault Relay N.C.	Fault Relay N.O.	Fault Relay N.C.	Fault Relay N.O.
5					
6	Alarm Relay N.O.	Alarm Relay N.O.	Alarm Relay N.O.	Alarm Relay N.O.	Alarm Relay N.O.
7	Alarm Relay C	Alarm Relay C	Alarm Relay C	Alarm Relay C	Alarm Relay C
8	0-20mA In	Alarm Relay N.C.	Alarm Relay N.C.	Auxiliary N.O.	Auxiliary N.O.
9	0-20mA Out	0-20mA Out*	0-20mA Out*	Auxiliary C	Auxiliary C
10	RS-485+ (1)	RS-485+ (1)	RS-485+ (1)	RS-485+ (1)	RS-485+ (1)
11	RS-485- (1)	RS-485- (1)	RS-485- (1)	RS-485- (1)	RS-485- (1)
12	RS-485 GND	RS-485 GND	RS-485 GND	RS-485 GND	RS-485 GND

*Available with the HART protocol.

Notes:

- RS-485 is used for communication network as specified in *Appendix C* (Terminals 10, 11 and 12).
- Alarm relay:
 - N.O. energized contact in wiring options 1, 4 and 5
 - N.O. and N.C. energized in options 2 and 3.
- 0-20mA is 'Sink' in option 1 and 'Source' in options 2 and 3.
- In Wiring Option 1, link Terminals 1 and 8 to change the mA output to 'Source'.
- 0-20mA 'Source' in options 2 and 3 available with the HART protocol.

- The Fault output is N.C. energized SPST relay. The contacts are closed when the Detector is in its normal operational condition in options 1, 2 and 4, and available as N.O. energized in options 3 and 5.
- The Auxiliary output is N.O. energized (SPST) relay. The Auxiliary Relay may act in parallel with the ALARM relay to activate another external device or it may provide a warning signal, depending on the function configuration.

2.8 CONFIGURING YOUR DETECTOR

You can reprogram the function setup using the RS-485 connection or using the Hart Protocol as follows:

- **Sierra Monitor Host Software:** The Sierra Monitor Host Software is for use on a PC or laptop. Refer to Manual TM777050 for programming instructions. The Host software enables you to change the functions.
- **Handheld Unit:** Refer to Manual 777060 for programming instructions when using the Handheld Unit. The connection to the Handheld is fast and intrinsically safe. It enables you to change the functions in situ with no need to remove the detector.
Note: Sierra Monitor can provide a suitable cable (P/N 794079-5) with integral RS485/USB converter to connect between the Detector and a PC/laptop.
- **Hart Protocol:** Refer to Manual TM 777030 for programming instructions.

These functions enable you to set:

- Alarm Delay
- Time Delay for Anti Flare mode
- Address Setup
- Mode of Operation
- Heated Optics Operation

The factory Default settings listed for each function are:

- Alarm Delay – 3 Sec.
- Alarm Latch – No
- Auxiliary Relay – No
- Automatic BIT – Yes
- Alarm BIT – No
- Auxiliary BIT – No
- EOL – No
- Heated Optics – Auto
- Temperature – 41°F (5°C)

2.8.1 ALARM DELAY

The detector is equipped with an Alarm Delay option, which provides programmable time delays with settings at:

- Antiflare* (default)

*The Antiflare mode is selected to prevent false alarms in locations where fast flares may be present. The Time Delay for fire alarms in this mode ranges from 2.5 to 15 seconds (usually, less than 10 seconds).

Other delays settings are available: 0, 3, 5, 10, 15, 20 or 30 seconds

When an Alarm (Detection) level condition occurs, the detector delays the execution of the Alarm outputs by the specified period of time. The detector then evaluates the condition for 3 seconds. If the Alarm level is still present, the Alarm outputs are activated. If this condition no longer exists, the detector returns to its standby state.

The Alarm delay option affects the output relays and the 0-20mA. The LEDs and outputs indicate warning levels during the delay time only if the fire condition exists.

2.8.2 ADDRESS SET-UP

The detector provides up to 247 addresses that can be changed with RS485 communication link or HART Protocol.

2.8.3 FUNCTION SET-UP

You can select the desired functions as detailed in the following table.

Table 17: Functions

Function	Setting
Alarm Latch	<ul style="list-style-type: none"> • Yes: Enable Alarm latching. • No: Disable Alarm latching (default).
Auxiliary Relay**	<ul style="list-style-type: none"> • Yes: Activate Auxiliary Relay at Warning level. • No: Activate Auxiliary Relay at Alarm level (default).
Automatic BIT	<ul style="list-style-type: none"> • Yes: Perform Automatic and Manual Bit (default). • No: Perform Manual Bit only.
Alarm BIT	<ul style="list-style-type: none"> • Yes: Successful Manual Bit activates the Alarm Relay for approximately 3 seconds (default). • No: Successful Manual Bit does not activate the Alarm Relay.
Auxiliary BIT**	<ul style="list-style-type: none"> • Yes: Successful Manual Bit activates the Auxiliary Relay for approximately 3 seconds (default). • No: Successful Manual Bit does not activate the Auxiliary Relay.
EOL**	<ul style="list-style-type: none"> • Yes: Auxiliary Relay is used as End of Line • No: Auxiliary Relay operates in accordance with Function 2 and 5 (default)

Note: ** only available in Model 3600U and UB-4XXXX and 5XXXX

2.8.4 HEATED OPTICS

The heated optics can be defined as one of the following modes:

- Heated Mode
 - OFF: Not operated
 - On: Continuously
 - AUTO: Per temperature change

In AUTO mode, the default HEAT ON setting is 41°F (5°C). Heating stops when the temperature is 27°F (15°C) above the start temperature.

You can define the start temperature below which the window will be heated. The temperature can be defined between 32°F and 122°F (0°C to 50°C).

3 OPERATING THE DETECTOR

➤ **In this chapter...**

<i>Powering Up</i>	<i>page 27</i>
<i>Safety Precautions</i>	<i>page 28</i>
<i>Testing Procedures</i>	<i>page 29</i>

This chapter describes how to power up and test the detector. It also includes some very important safety checks that you should make before operating the detector.

3.1 POWERING UP

This section describes how to power up the detector. Follow these instructions carefully to obtain optimal performance from the detector over its life cycle:

➤ **To power up the detector:**

- 1 Turn on the power.
- 2 Wait approximately 60 seconds for the detector to finish the start-up procedure.

Applying power initiates the following sequence of events:

- The yellow LED flashes at 4 Hz.
- BIT is executed.

If successful, the green LED flashes at 1 Hz and the FAULT relay contacts close, mA output is 4mA.

- 3 Enter to Normal mode.

Note: The majority of detectors are used in the default non-latching alarm mode. Only perform a Reset when the Latching alarm option has been programmed.

➤ **To reset a detector when in it is in a LATCHED ALARM state:**

- Do one of the following:
 - Disconnect power (Terminal Number 1 or Terminal Number 2).
 - or
 - Initiate a Manual BIT.

3.2 SAFETY PRECAUTIONS

After powering-up, the detector requires almost no attention in order to function properly, but the following should be noted:

- Follow the instructions in this guide and refer to the drawings and specifications.
- Do not expose the detector to radiation of any kind unless required for testing purposes.
- Do not open the detector housing, while power is applied.
- Do not open the electronic compartment. This part should be kept closed at all times and only opened in the factory. Opening the electronic component side invalidates the warranty.
- You should only access the wiring compartment to wire or remove the detector or access RS485 terminals for maintenance.
- Disconnect or disable external devices, such as automatic extinguishing systems before carrying out any maintenance.

3.2.1 DEFAULT FUNCTIONS SETTINGS

Table 18 lists the default function configuration supplied with the detector.

Table 18: Default Function Values

Function	Value	Notes
Sensitivity	30	
Alarm Delay	A	Antiflare
Alarm Latch	No	
Auxiliary Relay	No	In wiring options 1, 2, 3 the Auxiliary Relay is not available. This function is not used.
Automatic BIT	Yes	
Alarm BIT	No	
Auxiliary BIT	No	In wiring options 1, 2, 3 the Auxiliary Relay is not available. This function is not used.
EOL	No	In wiring options 1, 2, 3 the Auxiliary Relay is not available. This function is not used.
Heat Mode	Auto	
Heat On	41°F (5°C)	The detector starts heating the window for any temperature below this value (in degrees Celsius).

- In order to change the default function use:
 - P.C with Sierra Monitor software, refer to Manual 777050 for instructions.
 - Handheld unit, refer to Manual 777060 for instructions.
 - USB cable with 485 converter (1meter) part number 794079-5.
 - HART Protocol, refer to Manual 777030 for instructions.

3.3 TESTING PROCEDURES

This section describes the proof testing procedure for proper operation of the detector. The detector can be tested using the Manual Built-in-Test or the Sierra Monitor UV/IR Fire Simulator - 20/20-311.

The detector performs internal test continuously and automatic BIT test every 15 minutes for more details refer to *Built-In-Test (BIT)* on page 14.

This section includes the following topics:

- Automatic BIT Test, page 29
- Manual BIT Test, page 29
- Testing with Fire Simulator Model 20/20-311, page 30.

3.3.1 AUTOMATIC BIT TEST

Check that the indicators show normal conditions. See *Powering Up* on page 27.

3.3.2 MANUAL BIT TEST

Important: If the function setup **Alarm BIT** and/or **Auxiliary BIT** are set to **Yes** (default **No**), the Alarm, Auxiliary Relay and 0-20mA outputs are activated during a Manual BIT. Therefore, automatic extinguishing systems or any external devices that may be activated during BIT must be disconnected.

➤ **To perform a Manual BIT:**

- 1 Verify that the detector is Normal Mode.
- 2 Initiate Manual BIT. The results of successful and unsuccessful manual BITs are detailed in Table 11 and Table 12.

3.3.3 TESTING WITH FIRE SIMULATOR MODEL 20/20-311

The Fire Simulator Model 20/20-311 can be used to simulate exposure of the detector to a real fire condition. The detector is exposed to radiation at the required detection level. As a result, the detector will generate a Fire Alarm signal. See *Long Range UV/IR Fire Simulator* on page 47 for more information.

Important: If the detector is exposed to a fire simulator, the Alarm and Accessory Relays and 0-20mA are activated during the simulation. Therefore, automatic extinguishing systems or any external devices, which may be activated during this process, must be disconnected.

➤ **To perform Fire Simulator Test:**

- 1 Power up the system and wait up to 60 seconds for the detector to turn to a normal state. The Power LED turns on.
- 2 Aim the Sierra Monitor Fire Simulator Model 20/20-311 at the target point of the detector (Figure 14), in a way that the radiation emitted by it is facing directly towards the detector. (See *Long Range UV/IR Fire Simulator* on page 47).
- 3 Press the operation button once. After few seconds, a successful test shows the results shown in Table 19.

Table 19: Results of Successful Fire Simulator Test

Component	Action	Notes
0-20mA	Turn to 20mA	For a few seconds and then return to 4mA
Alarm Relay	Activated	for a few seconds and then returns to Normal
Auxiliary Relay	Activated	for a few seconds and then returns to Normal
Fault Relay	Remains active during the test	
LED	Red, steady	

The detector is now ready for operation.

4 MAINTENANCE AND TROUBLESHOOTING

➤ **In this chapter...**

<i>Maintenance</i>	<i>page 31</i>
<i>Troubleshooting</i>	<i>page 33</i>

This chapter deals with preventive maintenance, describes possible faults in detector operation and indicates corrective measures. Ignoring these instructions may cause problems with the detector and may invalidate the warranty. Whenever a unit requires service, please contact Sierra Monitor or its authorized distributor for assistance.

4.1 MAINTENANCE

This section describes the basic maintenance steps that should be taken to keep the detector in good working condition and includes the following topics:

- General Procedures, page 31
- Periodic Procedures, page 31
- Keeping Maintenance Records, page 32

4.1.1 GENERAL PROCEDURES

Maintenance should be performed by suitably qualified personnel, who are familiar with local codes and practice. Maintenance requires ordinary tools.

4.1.1.1 CLEANING

The detector must be kept as clean as possible. Clean the viewing window and the reflector of the Flame Detector periodically.

The frequency of cleaning operations depends upon the local environmental conditions and specific applications. The fire detection system designer will give his recommendations.

➤ **To clean the detector viewing window and reflector:**

- 1 Disconnect power to the detector before proceeding with any maintenance including window/lens cleaning.
- 2 Use water and detergent, and then rinse the viewing window with clean water.
- 3 Where dust, dirt or moisture accumulates on the window, first clean it with a soft optical cloth and detergent, and then rinse with clean water.

4.1.2 PERIODIC PROCEDURES

In addition to preventive cleaning and maintenance, the detector should be functionally tested every six months or as dictated by local codes and regulations. These tests should also be carried out if the detector has been opened for any reason.

4.1.2.1 POWER-UP PROCEDURE

Perform Power-Up procedure every time power is restored to the system. Follow the instructions described in *Powering Up* on page 27.

4.1.2.2 FUNCTIONAL TEST PROCEDURE

Perform a functional test of the detector as described in *Internal Detector Tests* on page 13.

4.1.3 KEEPING MAINTENANCE RECORDS

It is recommended that maintenance operations performed on a detector are recorded in a Log-book. The record should include the following:

- Installation date, and contractor
- Serial and tag no.
- Entries for every maintenance operation performed, including the description of the operation, date and personnel ID.

If a unit is sent to Sierra Monitor or a distributor for service, a copy of the maintenance records should accompany it.

4.2 TROUBLESHOOTING

This section is intended to be a guide to correct problems which may happen during normal operation.

Table 20: Troubleshooting Table

Problem	Cause	Corrective Action
LEDs Off Fault Relay at N.O. 0-20mA at 0mA	No power at the unit	<ul style="list-style-type: none"> • Check that the correct power is sent to the detector. • Check power polarity. • Check wiring in the detector. • Send the detector for repairs.
Yellow LED flashes at 4 Hz Fault Relay at N.O. 0-20mA at 0mA	Fault Detector <ul style="list-style-type: none"> • Low Voltage • Faulty Detector 	<ul style="list-style-type: none"> • Check the voltage at the detector; verify at least 24V at the detector terminal. • Send the detector for repairs.
Yellow LED flashes at 4 Hz Fault Relay at N.O. 0-20mA at 2mA	BIT Fault <ul style="list-style-type: none"> • Faulty Detector 	<ul style="list-style-type: none"> • Clean detector window • Re-power the detector • Replace the detector
Red LED constantly on	If no fire exists, then, Detector alarm latched	Perform Reset to the detector
Alarm Relay at On 0-20mA at 20mA	Alarm condition	<ul style="list-style-type: none"> • Check cause for alarm • If no alarm, re-power the detector • Send the detector back for repair

APPENDICES

A SPECIFICATIONS

➤ **In this appendix...**

<i>Technical Specifications</i>	<i>page 35</i>
<i>Electrical Specifications</i>	<i>page 36</i>
<i>Outputs</i>	<i>page 36</i>
<i>Mechanical Specifications</i>	<i>page 38</i>
<i>Dimensions</i>	<i>page 39</i>
<i>Weight</i>	<i>page 39</i>
<i>Environmental Specifications</i>	<i>page 39</i>

A.1 TECHNICAL SPECIFICATIONS

Spectral Response UV 0.185-0.260 μm

Detection Range
(at highest Sensitivity Setting for
1ft² (0.1m²) pan fire)

Fuel	ft. / m	Fuel	ft. / m
n-Heptane	50 / 15	Kerosene	37 / 11
Gasoline	50 / 15	Ethanol 95%	37 / 11
Diesel Fuel	37 / 11	Methanol	37 / 11
JP5	37 / 11	IPA (Isopropyl Alcohol)	37 / 11
Hydrogen	33 / 10	Polypropylene Pellets	18 / 15
Methane*	16 / 5	Office Paper	20 / 06
LPG*	40 / 12		

* 20" (0.5m) high, 8" (0.2m) width plume fire

Response Time Typically 3 seconds

Adjustable Time Delay Up to 30 seconds

Sensitivity Ranges 1 ft² (0.1m²) n-heptane pan fire from 50 ft. (15m)

Fields of View Horizontal 100°, Vertical 95°

Built-In-Test (BIT) Automatic (and Manual)

A.2 ELECTRICAL SPECIFICATIONS

Table 21: Electrical Specifications

Operating Voltage	Status	All Outputs	Without 4-20mA
Power Consumption (Max. 24VDC)	Normal	1.61W	1.56W
	Normal when Heater On	2.28W	2.16W
	Alarm	2.64W	2.28W
	Alarm when Heater On	3.24W	2.88W
Maximum Current (Max. 24VDC)	Normal	70mA	65mA
	Normal when Heater On	95mA	90mA
	Alarm	110mA	95mA
	Alarm when Heater On	135mA	120mA
Power Consumption (Max. 18-32VDC)	Normal	1.95W	1.85W
	Normal when Heater On	2.56W	2.45W
	Alarm	3.04W	2.56W
	Alarm when Heater On	3.68W	3.2W
Maximum Current (18-32VDC)	Normal	90mA	85mA
	Normal when Heater On	105mA	100mA
	Alarm	130mA	115mA
	Alarm when Heater On	160mA	145mA

Electrical Input Protection The input circuit is protected against voltage-reversed polarity, voltage transients, surges and spikes according to MIL-STD-1275B

A.3 OUTPUTS

Electrical Interface There are five output-wiring options. These options must be defined at the factory per the customer order and cannot be changed at the customer facility.

See *General Instructions for Electrical Wiring* on page 41 for the wiring/terminal diagram for each option.

Unless otherwise specified, the default is Option 1. The wiring arrangement is identified on the detector by the part number (see *Model and Types* on page 2).

- **Option 1:** Power, RS-485, 0-20mA (Sink), Fault I Relay (N.C), Alarm Relay, (N.O) (see Figure 7).
- **Option 2:** Power, RS-485, 0-20mA (Source) and HART protocol, Fault Relay (N.O), Alarm Relay, (N.O), (N.C).
- **Option 3:** Power, RS-485, 0-20mA (Source) and HART Protocol, Fault Relay (N.O), Alarm Relay (N.O, N.C).
- **Option 4:** Power, RS-485, Fault Relay (N.C), Auxiliary Relay

**Electrical
Outputs**

- (N.O), Alarm Relay, (N.O).
- **Option 5:** Power, RS-485, Fault Relay (N.O), Auxiliary Relay (N.O), Alarm Relay, (N.O).
- **Dry Contact Relays**

Table 22: Contact Ratings

Relay Name	Type	Normal Position	Maximum Ratings
Alarm	DPST	N.O., N.C.	2A at 30 VDC or 0.5A at 250 VAC
Auxiliary	SPST	N.O.	5A at 30 VDC or 250 VAC
Fault *	SPST	N.C. or N.O	5A at 30 VDC or 250 VAC

Notes:

- The Fault relay (in wiring options 1, 2, 4) is normally energized closed during normal operation of the detector. The relay is de-energized open if a fault condition or low voltage situation occurs.
- * In wiring options 3, 5 the relay is normally energized open during normal operation of the detector. The relay is de-energized close contact if a fault condition or low voltage situation occurs.
- **0-20mA Current Output:** The 0-20mA can be Sink or Source according to the wiring option source (see *General Instructions for Electrical Wiring* on page 41). The maximum permitted load resistance is 600Ω.

Table 23: 20 mA Current Output

State	Output
Fault	0 □ 1 mA
BIT Fault	2 mA±10%
Normal	4 mA±10%
Warning	16 mA±5%
Alarm	20 mA±5%

- **HART Protocol**
The HART is a digital communication signal at a low level on top of the 0-20mA. This is a bi-directional field communication protocol used to communicate between intelligent field instruments and the host system. HART is available in wiring options 2 and 3.
Through HART protocol the detector can:
 - Display set-up

- Reconfigure the set-up
- Display detector status and definition
- Perform detector diagnostics
- Troubleshoot

For more details refer to *HART Manual 777030*.

- **Communication Network:** The detector is equipped with an RS-485 communication link that can be used in installations with computerized controllers.

The communications protocol is Modbus compatible.

- This protocol is a standard and widely used.
- It enables continuous communication between a standard Modbus controller (Master device) and a serial Network of up to 247 detectors.

Heated Optics The front window can be heated to improve performance in icing, condensation and snow conditions. The heater increases the temperature of the optical surface by 5-8°F (3-5°C) above the ambient temperature. The heated optics can be configured in three ways:

- **Off:** The optics are not heated
- **On:** The optics are heated continuously
- **Auto:** Operated only when the change of temperature requires the heating. (default)

In **Auto** mode the start heating temperature can be defined between 32°F - 122°F (0°C - 50°C). The detector stops heating the window when the temperature is 27°F (15°C) above the start temperature.

A.4 MECHANICAL SPECIFICATIONS

Enclosure	Stainless Steel 316 or Aluminum, heavy duty copper free (less than-1%), red epoxy enamel finish
Hazardous Area Approvals	<ul style="list-style-type: none"> • FM, CSA Class I Div. 1 Groups B, C and D; Class II/III Div. 1 Groups E, F and G. • ATEX, IECEx ; EX II 2 GD, EExde IIB + H2 T5 (75°C), T4 (85°C)
Water and Dust Tight	<ul style="list-style-type: none"> • NEMA 250 type 6p. • IP 66 and IP 67 per EN 60529
Electronic Modules	Conformal coated
Electrical Connection (two entries)	<ul style="list-style-type: none"> • x ¾" - 14NPT conduit or • 2 x M25 (ISO)

A.5 DIMENSIONS

4" x 4.6" x 6.18" (101.6 x 117 x 157 mm)

A.6 WEIGHT

Stainless Steel: 6.1 lb. (2.8 kg)

Aluminium: 2.8 lb. (1.3 kg)

A.7 ENVIRONMENTAL SPECIFICATIONS

The 3600I is designed to withstand harsh environmental conditions.

- High Temperature**
 - Designed to meet MIL-STD-810C, method 501.1 procedure II
 - Operating temperature: +167°F (+75°C)
 - Storage temperature: +185 °F (+85°C)
- Low Temperature**
 - Designed to meet MIL-STD-810C, method 502.1, procedure I
 - Operating temperature: -57°F (-50°C)
 - Storage temperature: -65°F (-55°C)
- Humidity**
 - Designed to meet MIL-STD-810C, method 507.1, procedure IV
 - Relative humidity of up to 95% for the operational temperature range
- Salt Fog**
 - Designed to meet MIL-STD-810C, method 509.1, procedure I
 - Exposure to a 5% Salt Solution Fog for 48 hours
- Dust**
 - Designed to meet MIL-STD-810C, method 510.1, procedure I
 - Exposure to a dust concentration of 0.3 frames/cubic ft. at a velocity of 1750 fpm, for 12 hours
- Vibration**
 - Designed to meet MIL-STD-810C, method 514.2, procedure VIII
 - Vibration at an acceleration of 1.1g within the frequency range of 5-30 Hz, and an acceleration of 3g within the frequency range of 30-500 Hz
- Mechanical Shock**
 - Designed to meet MIL-STD-810C, method 516.2, procedure I
 - Mechanical Shock of 30g half-sine wave, for 11 msec
- Electromagnetic Compatibility (EMC)**
 - See Table 24

Table 24: Electromagnetic Compatibility (EMC)

	Test Standard	Level Per
Electrostatic Discharge ESD	IEC 61000-4-2	IEC 61326-3
Radiated EM Field	IEC 61000-4-3	IEC 61326-3
Electrical Fast Transients	IEC 61000-4-4	IEC 61326-3
Surge	IEC 61000-4-5	IEC 61326-3
Conducted Disturbances	IEC 61000-4-6	IEC 61326-3
Power Ferq. Magnetic Field	IEC 61000-4-8	IEC 61326-3
Radiated Emission	IEC 61000-6-3	EN 55022
Conducted Emission	IEC 61000-6-3	EN 55022
Immunity to Main Supply Voltage Variations	MIL-STD-1275B	

To fully comply with EMC directive and protect against interference caused by RFI and EMI, the cable to the detector must be shielded and the detector must be grounded. The shield should be grounded at the detector end.

B WIRING INSTRUCTIONS

➤ In this appendix...

<i>General Instructions for Electrical Wiring</i>	<i>page 41</i>
<i>Typical Wiring Configurations</i>	<i>page 42</i>

B.1 GENERAL INSTRUCTIONS FOR ELECTRICAL WIRING

Follow the instructions detailed in this section for determining the correct wire gauge to be used for the installation.

- 1 Use Table 25 to determine the required wire gauge /size for general wiring, such as relay wiring. Calculate the permitted voltage drop with respect to load current, wire gauge and length of wires.

Table 25: Maximum DC resistance at 68°F (20°C) for copper wire

AWG #	mm ²	Ohm per 100 ft.	Ohm per 100 m
26	0.12 - 0.15	4.32	14.15
24	0.16 - 0.24	3.42	11.22
22	0.30 - 0.38	1.71	5.60
20	0.51 - 0.61	1.07	3.50
18	0.81 - 0.96	0.67	2.20
16	1.22 - 1.43	0.43	1.40
14	1.94 - 2.28	0.27	0.88
12	3.09 - 3.40	0.17	0.55
10	4.56 - 6.64	0.11	0.35

- 2 Use Table 26 to select wire gauge for power supply wires. DO NOT connect any circuit or load to detectors' supply inputs.
 - Select **Number of detectors** connected in one circuit.
 - Select wiring **Length** per your installation requirements.
 - Refer to **Power Supply Range** for voltage extreme applied.

Table 26: Wiring length in feet (meter)

Number of Detectors	Recommended Wire Diameter (AWG)					Power Supply Range (VDC)
	18	16	14	-	-	
24	18	16	14	-	-	22-32
20	18	16	14	-	-	22-32
16	20	18	16	14	-	22-32
12	20	18	16	14	-	20-32
8	20	18	16	14	-	20-32
4 and less	20	18	16	16	14	20-32
Ft (m)	164 (50)	328 (100)	492 (150)	656 (200)	820 (240)	
Max. Length from Power Supply to Last Detector						

B.2 TYPICAL WIRING CONFIGURATIONS

This section describes examples of typical wiring configurations.

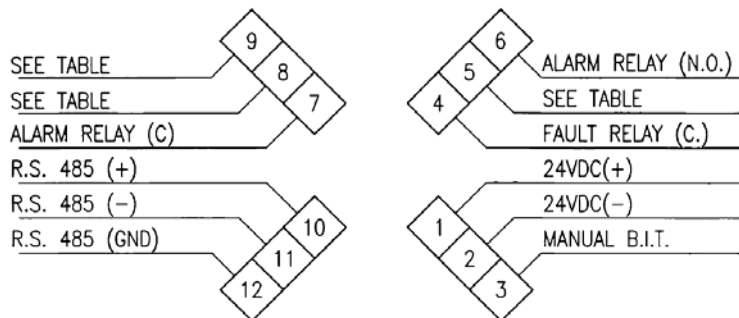

Figure 8: Wiring Terminals

Table 27: Wiring Connections

Wiring Option	Detector Model	Terminals		
		5	8	9
1	3600U ,UB-1XXXX	Fault Relay N.C.	0-20mA (Sink)	0-20mA (Sink)
2	3600U ,UB -2XXXX	Fault Relay N.C.	Alarm Relay N.C.	0-20mA Duct (Source)
3	3600U ,UB -3XXXX	Fault Relay N.O.	Alarm Relay N.C.	0-20mA Duct (Source)
4	3600U ,UB -4XXXX	Fault Relay N.C.	Auxiliary Relay N.O.	Auxiliary Relay (N.O.)
5	3600U ,UB -5XXXX	Fault Relay N.O.	Auxiliary Relay N.O.	Auxiliary Relay (N.O.)

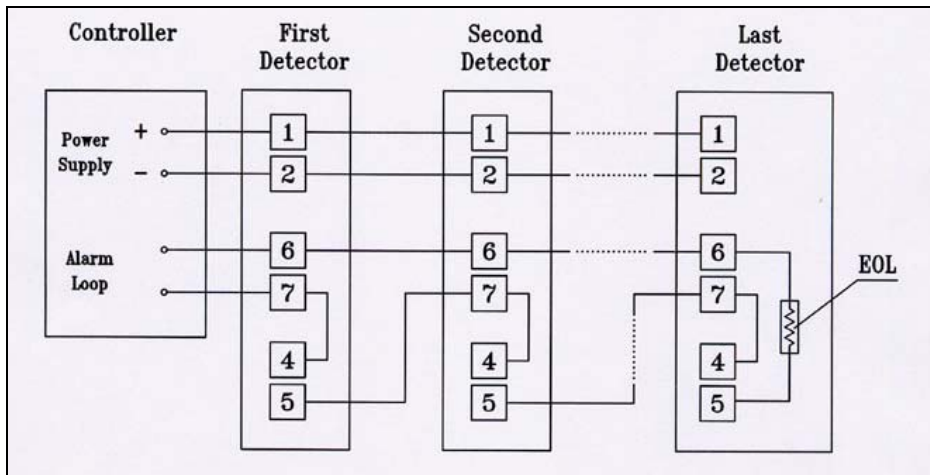

Figure 9: Typical Wiring For 4 Wire Controllers (Using Option 1 or 2 Wiring)

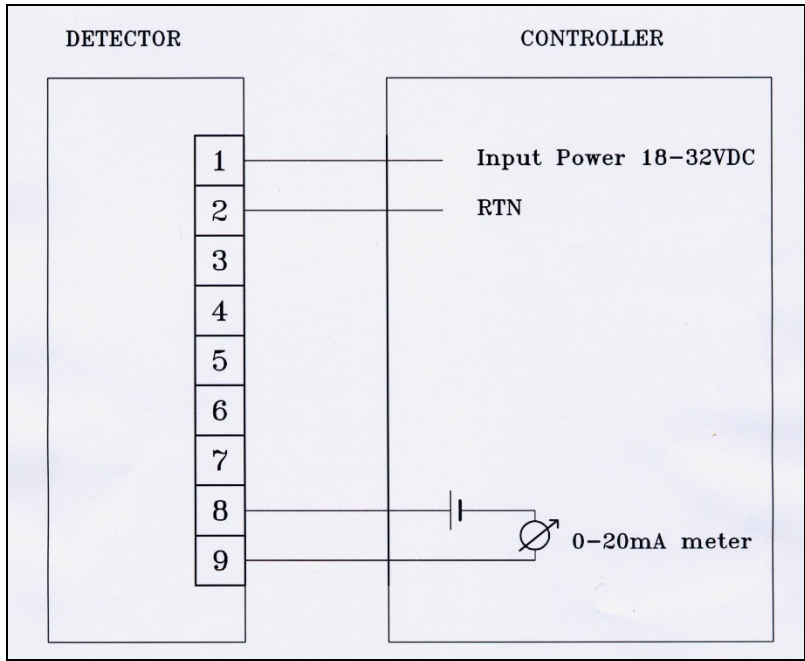

Figure 10: 0-20mA Wiring Option 1 (Sink 4-Wire) - Default

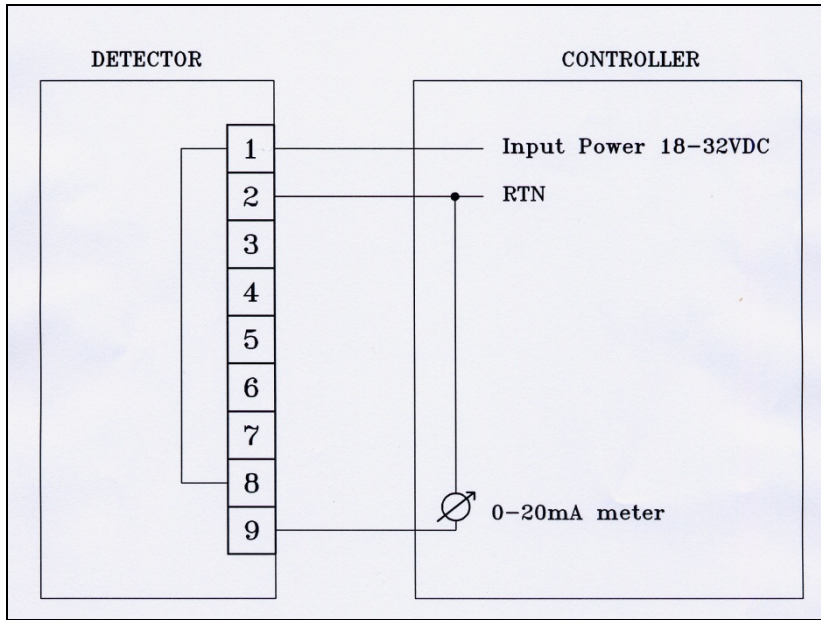

Figure 11: 0-2mA Wiring Option 1 (Converted to Source 3-Wire)

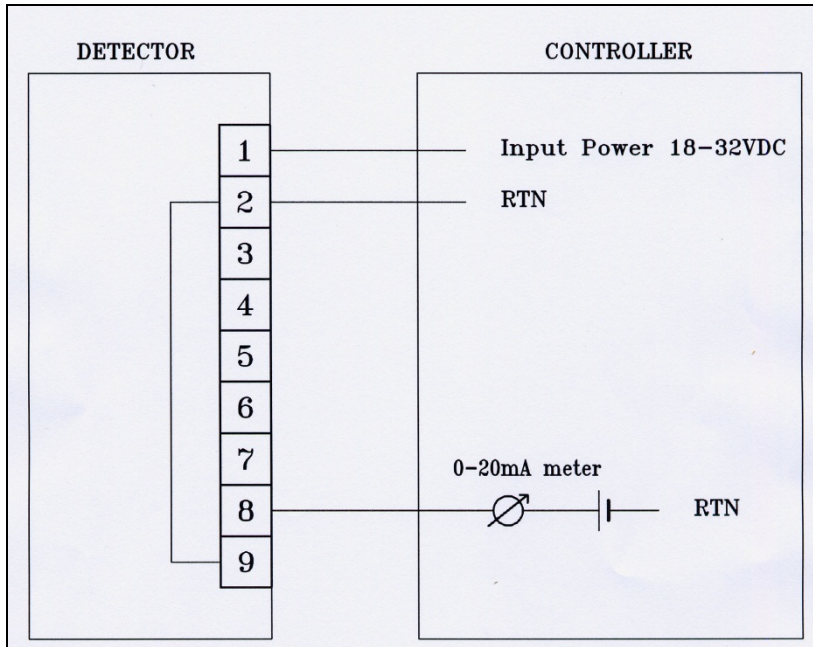

Figure 12: 0-20mA Wiring Option 1 (Unisolated Sink 3-Wire)

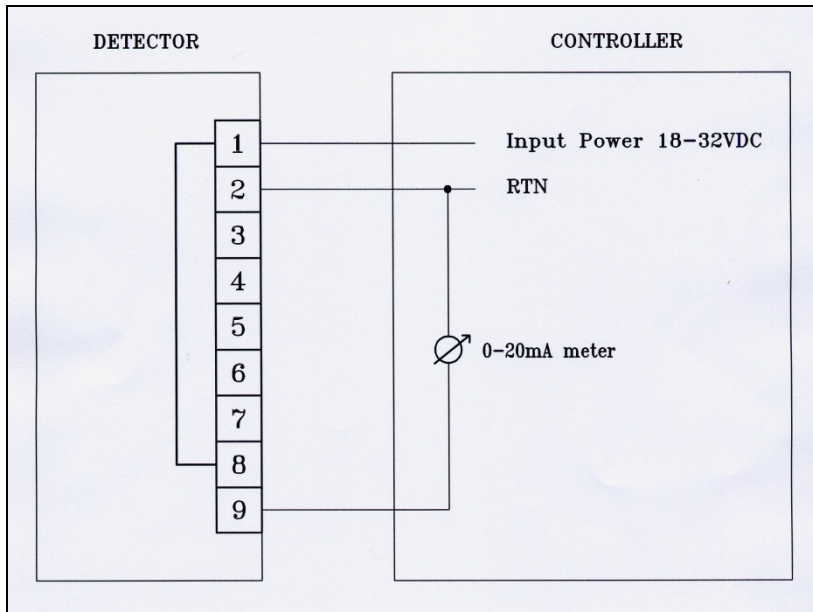

Figure 13: 0-20mA Wiring Option 2 and 3 (Source 3-Wire available with the HART protocol)

Note: There are no 0-20mA outputs in wiring options 4 and 5.

C RS-485 COMMUNICATION NETWORK

➤ In this appendix...

<i>RS-485 Overview</i>	<i>page 46</i>
------------------------	----------------

C.1 RS-485 OVERVIEW

By using the RS-485 network capability of the UV detector and additional software, it is possible to connect up to 32 detectors in an addressable system with four (4) wires only (2 for power and 2 for communication). Using repeaters, the number of detectors can be much larger (32 detectors for each repeater) up to 247 on the same four (4) wires. When using the RS-485 network, it is possible to read each detector status (FAULT, WARNING, and ALARM) and to initiate a BIT to each detector individually.

For more details, consult Sierra Monitor.

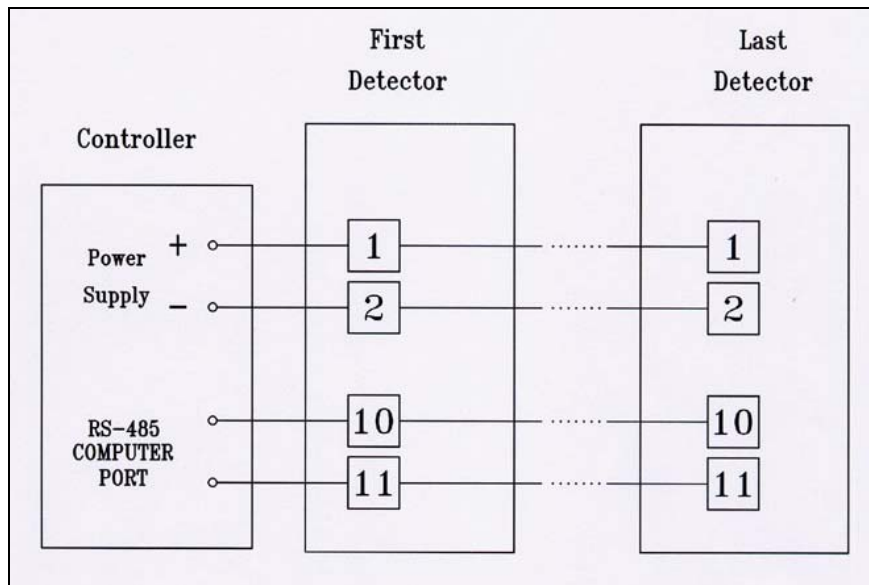

Figure 14: RS-485 Networking

D ACCESSORIES

➤ **In this appendix...**

<i>Long Range UV/IR Fire Simulator</i>	<i>page 47</i>
<i>Tilt Mount P/N 3600-001</i>	<i>page 50</i>
<i>Weather Protection – P/N 777163</i>	<i>page 51</i>
<i>Laser Detection Coverage Pointer – P/N 777166</i>	<i>page 52</i>
<i>Air Shield – P/N 777161</i>	<i>page 52</i>

This appendix describes the accessories that can help you maximize fire detection with the UV/IR flame detector:

D.1 LONG RANGE UV/IR FIRE SIMULATOR

The UV/IR Long Range Fire Simulator 20/20-311 is designed specifically for use with UV/IR and UV flame detectors. The Fire Simulator emits IR and UV radiation in a unique sequential pattern corresponding to and recognizable by the detector as fire. This allows the detectors to be tested under simulated fire conditions without the associated risks of an open flame.

There is an optional beam collimator, model no. 20/20-190, specially designed for extended test range.



Figure 15: UV/IR Long Range Fire Simulator 20/20-311

D.1.1 UNPACKING

Verify that you have received the following contents:

- Delivery form
- Fire Simulator with integral batteries
- Battery charger
- Optional Beam Collimator
- Storage case

D.1.2 OPERATING INSTRUCTIONS

Warning: Do not open the Fire Simulator to charge the batteries or for any other reason in a hazardous area.

Caution: The following test simulates a real fire condition and may activate the extinguishing system or other alarms. If this is not desired, disconnect/inhibit them before the test and reconnect after the simulation.

➤ **To simulate a fire:**

- 1 Aim the Fire Simulator towards the detector's Target Point.

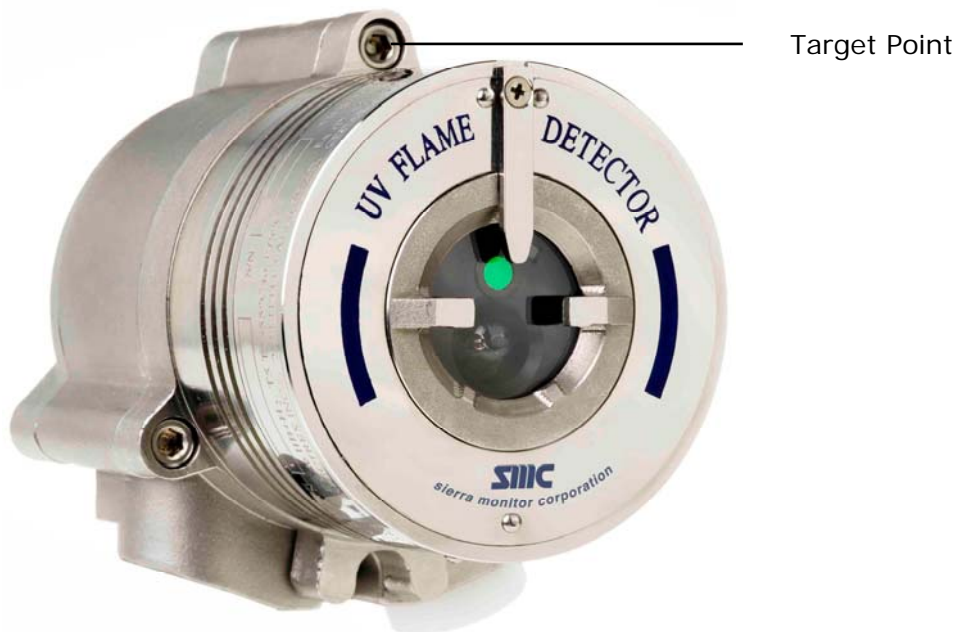

Figure 16: 3600U and UB Detector Target Point

- 2 When testing keep a distance of at least 50 cm (20 inches) from the detector.
- 3 Press the operation button once. Fire simulation lasts for 20 seconds. The detector sends an alarm signal (solid red LED).
- 4 Wait 20 seconds before repeating the test.
- 5 Verify that the optical window is clean.

D.1.3 RANGE

Table 28: Sensitivity Ranges

Detector Model	Standard Test Range(ft./m)	Extended Test Range with collimator (ft./m)
40U	14.5/ (4.5)	29 / 9
40UB	14.5/ (4.5)	29 / 9

Notes:

- The minimum distance from the detector is 20 inches (50 cm).
- The optional beam collimator is fitted for Extended Range.
At extreme temperatures, there is a 15% maximum reduction in the range

Important: Keep the Fire Simulator in a safe place when not in use.

D.1.4 CHARGING THE BATTERY

The Fire Simulator uses NiCd batteries as a rechargeable power source. When the batteries are fully charged, the simulator operates for at least 60 times without recharging. An internal buzzer is sounded when the voltage from the batteries is lower than the required operational level.

➤ **To charge the battery:**

- 1 Place the Fire Simulator on a table in a safe area.
- 2 Turn the sealed plug (next to the operation button) counter-clockwise with a suitable wrench.
- 3 Connect the battery charger.
- 4 Charge for a maximum of 14 hours.
- 5 Disconnect the charger
- 6 Tighten the sealed plug clockwise.

D.1.5 TECHNICAL SPECIFICATIONS

Mechanical	<ul style="list-style-type: none">• Explosion Proof Enclosure:• NFPA (designed to meet)• Class I, Division 1 & 2 Groups B, C and D• Class II, Division 1 & 2 Groups E, F and G• ATEX EX II2G NEMKO 02ATEX255• EExd IIB T5 50°C per En 50-014 & EN50-018
Electrical	<ul style="list-style-type: none">• Power: 8 VDC Max.• 6 x Rechargeable 1.2 VDC NiCd Batteries• Current: 2.5A Avg.• Charge: 400 mA for 14 Hours
Environment	<ul style="list-style-type: none">• Temperature Range: -4°F to +122°F (-20°C to +50°C)• Vibration Protection: 1g (10-50hz)• Water and Dust: IP 67 per EN 60529
Physical	<ul style="list-style-type: none">• Dimensions: 11.5 x 10.1 x 3.9 in (292 x 258 x 100 mm)• Weight: 7.5 lb. (3.4 Kg)

D.2 TILT MOUNT P/N 3600-001

The Tilt mount provides accurate directional selection for optimum area coverage.

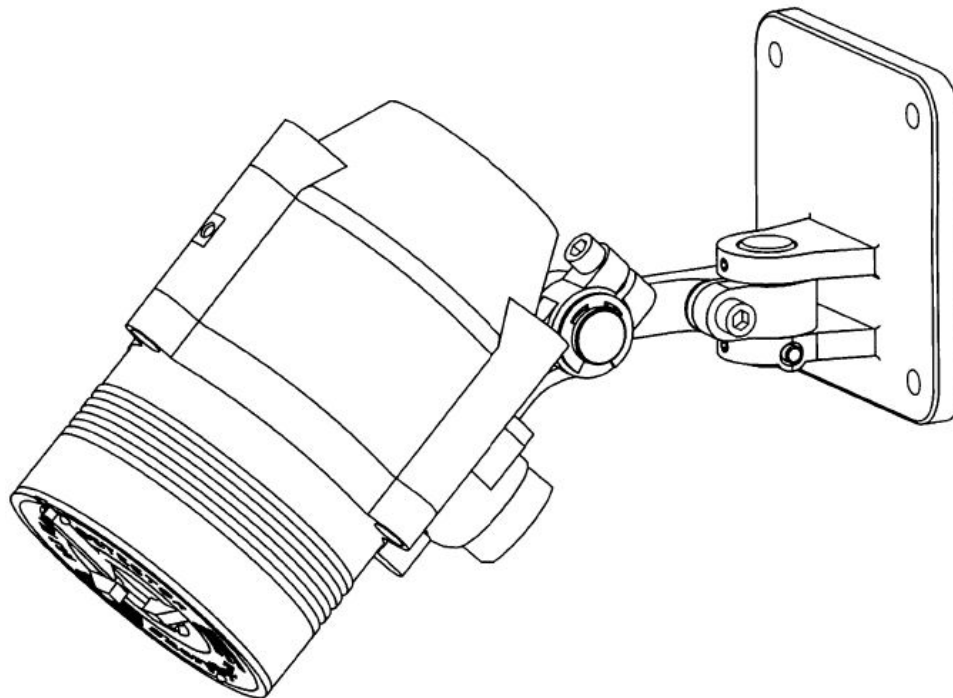

Figure 17: Tilt Mount

D.3 WEATHER PROTECTION – P/N 777163

The weather protector protects the detector from different weather conditions, such as snow and rain.

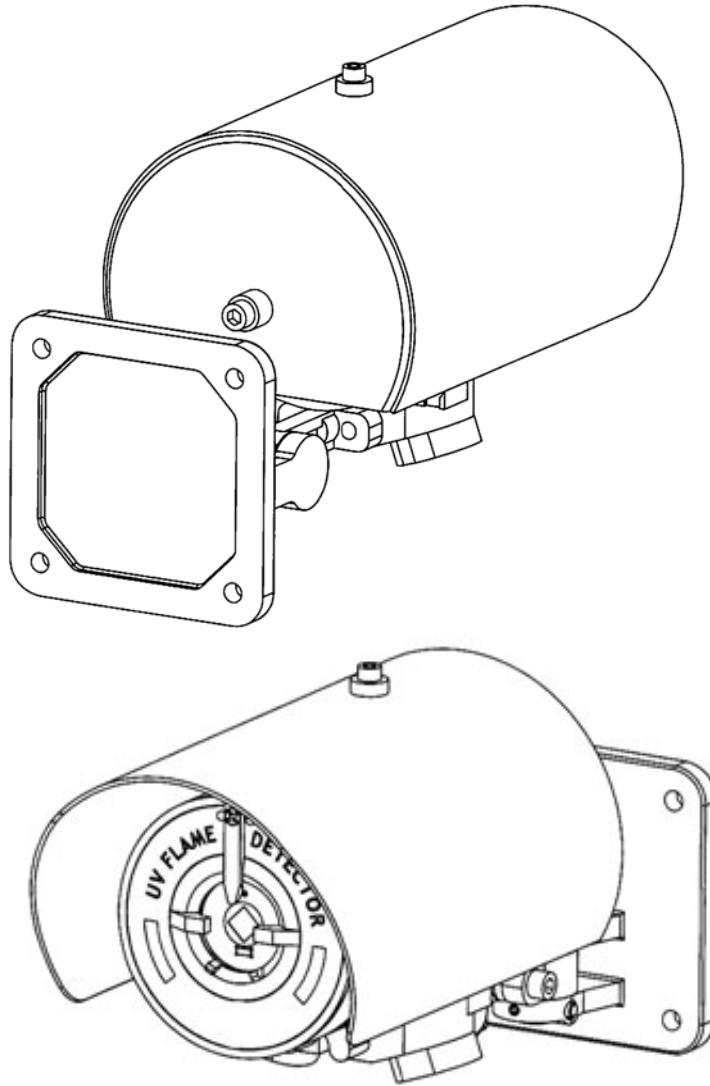

Figure 18: Weather Protection

D.4 LASER DETECTION COVERAGE POINTER – P/N 777166

The Laser Detection Coverage Pointer evaluates detector coverage on-site. The device is an add-on accessory that enables designers and installers to optimize detector location and assess the actual coverage of installed detectors.

The device is universal and can be used with all 3600 Optical Flame Detectors.

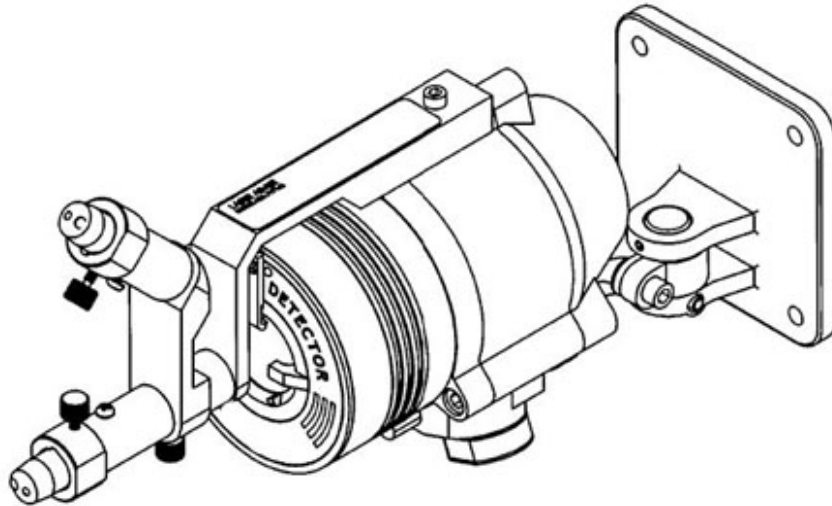

Figure 19: Laser Detection Coverage Pointer

D.5 AIR SHIELD – P/N 777161

The Air Shield enables you to install the detector in dirty areas and using compressed air, keep the window clean. This prevents the accumulation of dirt on the window and enables the detector to continue to operate under harsh conditions.

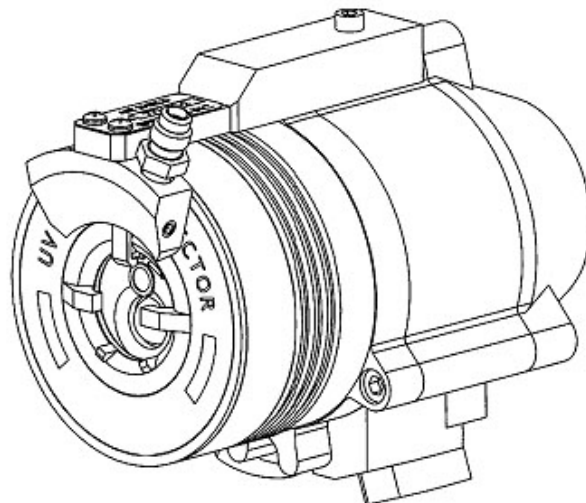

Figure 20: Air Shield

E SIL-2 FEATURES

➤ In this appendix...

3600U/UB Flame Detector	<i>page Error! Bookmark not defined.</i>
-------------------------	--

E.1 3600U/UB FLAME DETECTOR

This appendix details the special conditions to comply with the requirements of EN 61508 for SIL 2.

The 3600U/UB Flame Detector can only be used in low or high demand mode applications, see IEC 61508.4, Chapter 3.5.12.

E.1.1 SAFETY RELEVANT PARAMETERS

Perform the following functional check of the detector every 30 days:

- **HFT:** 0
- **PFD:** 2.5×10^{-5} ($\approx 0.2\%$ of SIL-2) if only Alarm Relay is used for alerting.
- **PFD:** 2.8×10^{-5} ($\approx 0.3\%$ of SIL-2) if 4-20mA interface is used as alarm.
- **SFF:** 97% fulfills the conditions of EN 61508 for SIL2

E.1.2 GUIDELINES FOR CONFIGURING, INSTALLING, OPERATING AND SERVICE

The alert conditions according to SIL 2 can be implemented by an:

- Alert signal via 20mA current loop
- or
- Alert signal via alarm relay and the fault relay

E.1.2.1 CONDITIONS FOR SAFE OPERATING

- 1 The flame detector shall consist only of the approved hardware and software modules.
- 2 The 24V power supply must fulfill the requirements for PELV / SELV of EN 60950.
- 3 The automatic BIT (Built-In-Test) must be activated.
- 4 The set-up parameters must be verified (as described in *Using the 0-20mA Interface for Alerting* on page 54, point 1 and in *Using the Alarm Relay Contact for Alerting* on page 54, point 1) and the function of the 3600 Flame Detector (flame detection, function of the 0-20mA interface, relay functions) must be checked completely.

E.1.2.2 USING THE 0-20MA INTERFACE FOR ALERTING

- 1 The following parameters shall be set:
 - AUTOMATIC BIT test = on
 - Connected to 0-20mA Terminals
- 2 The following allowed output current must be supervised with an accuracy of $\pm 5\%$:
 - Normal State = 4mA
 - Warning State = 16mA
 - Alarm State = 20mA
- 3 The output current must be supervised regarding the over-and under run of the 0-20mA.

E.1.2.3 USING THE ALARM RELAY CONTACT FOR ALERTING

- 1 The following parameters shall be set:
 - AUTOMATIC BIT Test = on
 - Connected to N.C. contact of Alarm Relay Terminals
 - Connected to Fault Relay Terminals
- 2 The relay contacts (“alarm” – and “faulty relay”) must be protected with a fuse rated at 0.6 of the nominal specified relay contact current.
- 3 The maximum contact rating that is allowed per SIL-2 is 30VDC.
- 4 It is to be considered that the contact of the Alarm Relay opens if there is a fire alarm.
- 5 During the forwarding and evaluation of the alarm it must be noted that the relay contact opens.
- 6 The alarm relay can be used as low demand only.

E.1.2.4 OTHER

- 1 The complete function of the flame detector (flame detection, function of the 0-20mA interface, the relays) must be examined at least every six or twelve months (see *Safety Relevant Parameters* on page 53, when the flame detector must be switched OFF and ON).
- 2 The window of the sensor must be examined at appropriate time intervals for partial contamination.
- 3 The HART and the RS 485 interfaces must not be used for the transmission of the safety-related data.

LIMITED WARRANTY

SIERRA MONITOR CORPORATION warrants its products to be free from defects in workmanship or material under normal use and service for two years after date of shipment. SMC will repair or replace without charge any equipment found to be defective during the warranty period. Final determination of the nature and responsibility for defective or damaged equipment will be made by SMC personnel.

All warranties hereunder are contingent upon proper use in the application for which the product was intended and do not cover products which have been modified or repaired without SMC approval or which have been subjected to accident, improper maintenance, installation or application, or on which original identification marks have been removed or altered. This Limited Warranty also will not apply to interconnecting cables or wires, consumables (i.e. calibration gases, batteries, sensors), nor to any damage resulting from battery leakage.

In all cases SMC's responsibility and liability under this warranty shall be limited to the cost of the equipment. The purchaser must obtain shipping instructions for the prepaid return of any item under this warranty provision and compliance with such instruction shall be a condition of this warranty.

Except for the express warranty stated above, SMC disclaims all warranties with regard to the products sold hereunder including all implied warranties of merchantability and fitness and the express warranties stated herein are in lieu of all obligations or liabilities on the part of SMC for damages including, but not limited to, consequential damages arising out of/or in connection with the use or performance of the product.